

APPROVED: _____
 DATE: _____ TITLE: _____

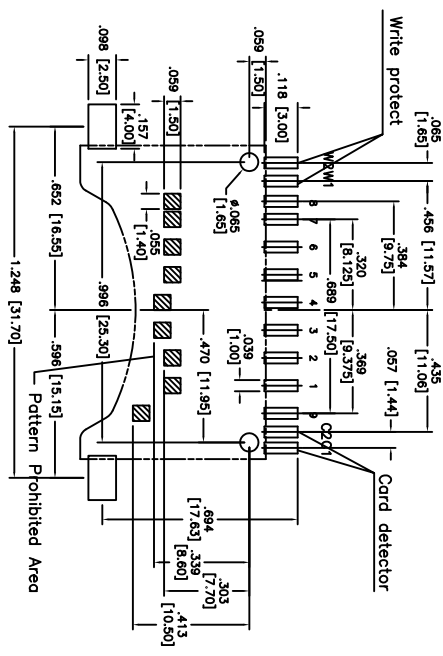

RECOMMENDED PCB LAYOUT

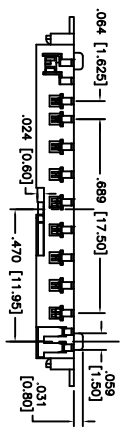
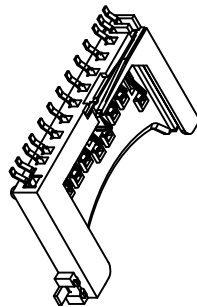
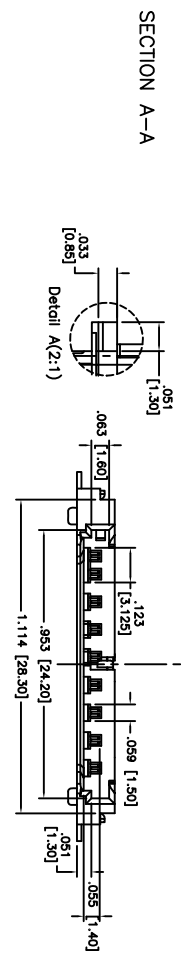
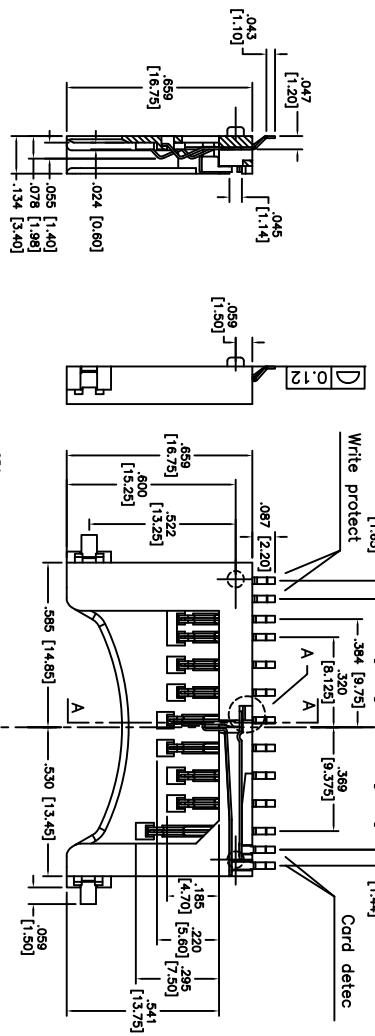
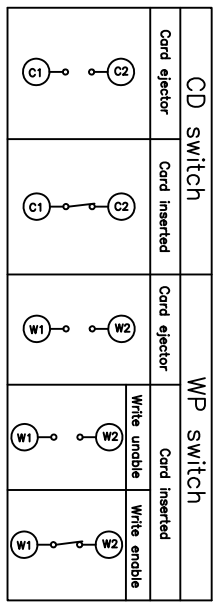

SPECIFICATIONS:

- Material: Insulator: Thermal Plastic, rated UL 94V-0
- Insulator color: Natural
- Contacts: Copper Alloy
- Plating: Gold Flash over Nickel underplate on contact area, Tin over Copper underplate on SMT tails
- Electrical: Current rating: 1 Amp max
- Contact resistance: 100 mohms
- Insulation resistance: 1000 Mohms min
- Mechanical: Mating Cycle: 10000 Cycles
- Temperature Rating: Operating temperature: -40°C to +85°C
- Environmental: Lead free, RoHS compliant.
- Recommended soldering temp: 260°C for 5 sec.



Rev	AWO #	Description	Date	Appr
-		RELEASED	2/16/06	
A		REDRAWN	10/16/09	

UNLESS OTHERWISE SPECIFIED	
ALL DIMENSIONS ARE INCHES [MM]	
TOLERANCES: EXCEPT AS NOTED	
INCHES	HOLES
.X ± .10	Ø.X ± .10
.XX ± .020	Ø.XX ± .015
.XXX ± .015	Ø.XXX ± .010
APPROVALS	
DRAWN	SS
CHECKED	
APPROVED	

ADAM TECH
 909 Rahway Avenue, Union, NJ 07083
 Phone: 908-687-5000 Fax: 908-687-5710

TITLE: SECURE DIGITAL SOCKET, 9 PIN
 NO STANDOFFS

SIZE: PART NO. SD-09-A-SG
 REF: S00009T SCALE: NTS SHEET 1 OF 1