

APPROVED: _____
 DATE: _____ TITLE: _____

Rev	AWO #	Description	Date	Appr
-		RELEASED	11/05/10	

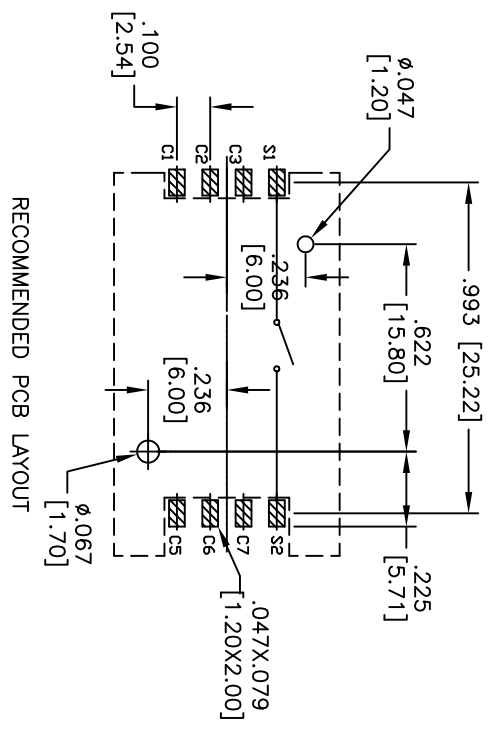
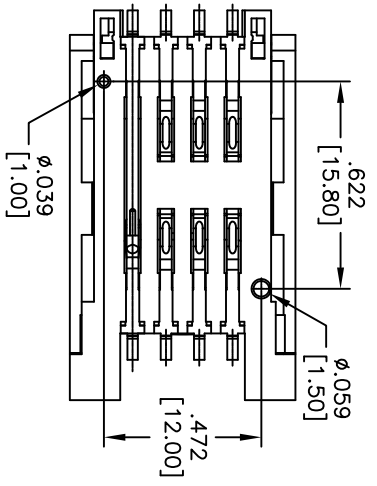
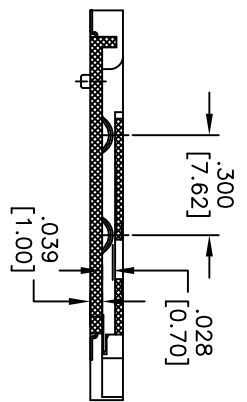
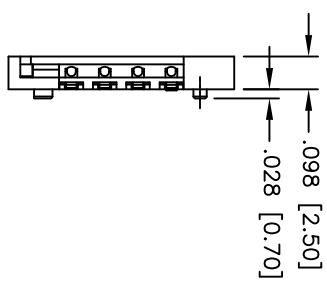
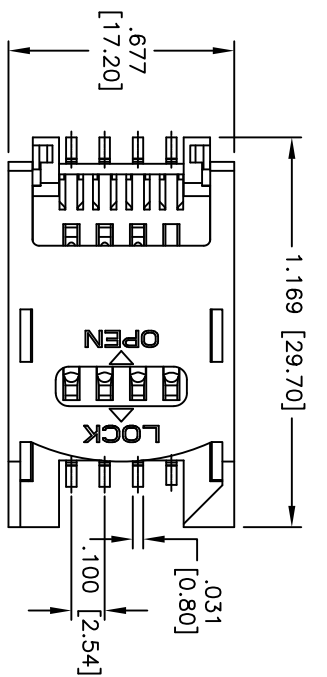

PACKAGED ON TAPE & REEL

RECOMMENDED PCB LAYOUT

SPECIFICATIONS:
 Material: Insulator: Hi-temp thermoplastic, rated UL 94V-0
 Insulator color: Black
 Contacts: Phosphor Bronze
 Plating: 15u" Gold over Nickel underplate on contact area, Tin over copper underplate on tails.
 Electrical:
 Current rating: 0.5 Amp max
 Contact resistance: 50 mohms max
 Insulation resistance: 1,000 Mohms min
 Dielectric withstanding voltage: 500 VAC for 1 minute
 Temperature Rating:
 Operating temperature: -25°C to +85°C
 Environmental:
 Lead free, RoHS compliant
 Recommended soldering temp: 260°C for 5 seconds



ADAM TECH

909 Railway Avenue, Union, NJ 07083
 Phone: 908-687-5000 Fax: 908-687-5710

TITLE
 SIM CARD 6 PIN, W/ HINGED COVER
 W/ PEG & SWITCH

UNLESS OTHERWISE SPECIFIED ALL DIMENSIONS ARE IN INCHES [MM]	
TOLERANCES: EXCEPT AS NOTED	
INCHES	MM
.X ± .10	ØX ± .10
.XX ± .020	ØXX ± .015
.XXX ± .015	ØXXX ± .010
APPROVALS	DATE
DRAWN	DY
CHECKED	
APPROVED	

SIZE	PART NO.	SCALE	SHEET 1 OF 1
X	SCC-A-06-SG-HC-15-T/R	NTS	
REF:	S00010T		