

6

5

4

3

2

1

APPROVED: \_\_\_\_\_  
 DATE: \_\_\_\_\_ TITLE: \_\_\_\_\_

Rev	AWO #	Description	Date	Appr
-	7629	RELEASED	3/20/07	
A	7629	REVISED TITLE	8/10/10	

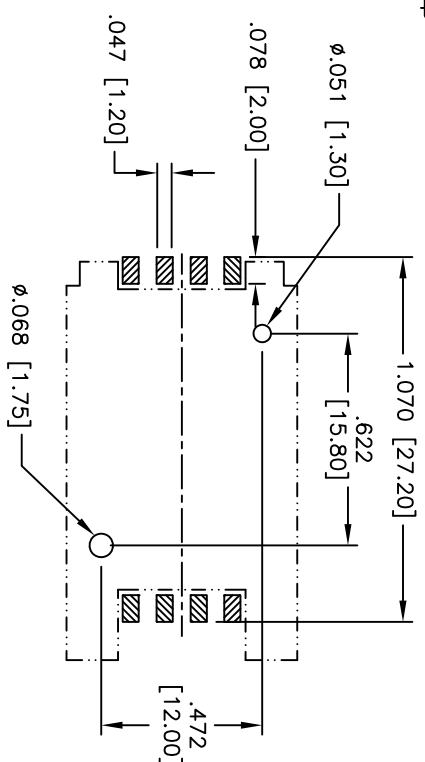
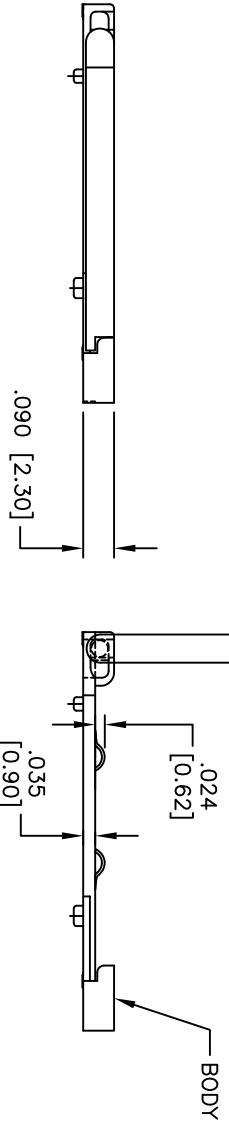
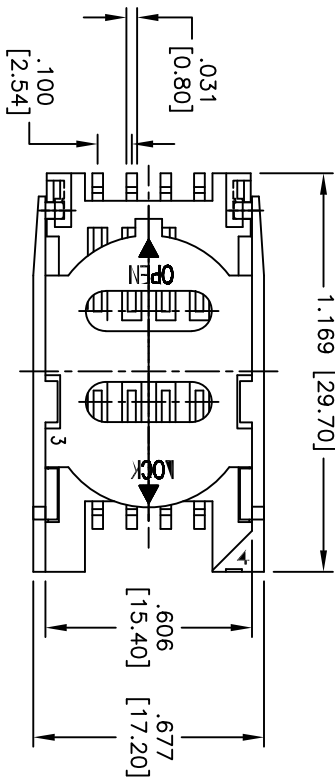

RECOMMENDED P.C.B. LAYOUT  
 TOP VIEW

**SPECIFICATIONS:**

Material: PPS, rated UL 94V-0  
 Insulator color: Black  
 Contacts: Phosphor Bronze  
 Plating: Gold flash over Nickel underplate on contact area, tin over copper underplate on tails.

Electrical:  
 Operating voltage: 250 VAC max  
 Current rating: 0.5 Amp max  
 Contact resistance: 30 mohms max  
 Insulation resistance: 1,000 Mohms min  
 Dielectric withstanding voltage: 500 VAC for 1 minute  
 Temperature Rating: Operating temperature: -25°C to +85°C



Environmental:  
 Lead free, RoHS compliant  
 Recommended soldering temp: 260°C for 5 seconds

UNLESS OTHERWISE SPECIFIED ALL DIMENSIONS ARE INCHES [MM]	
TOLERANCES: EXCEPT AS NOTED	
INCHES	HOLDS
.X ± .10	ØX ± .10
.XX ± .020	ØXX ± .015
.XXX ± .015	ØXXX ± .010
APPROVALS	DATE
DRAWN BW	3/20/07
CHECKED	
APPROVED	

**ADAM TECH**

909 Rahway Avenue, Union, NJ 07083  
 Phone: 908-687-5000 Fax: 908-687-5710

TITLE: SIM CARD 8 PIN WITH POST  
 W / HINGED COVER, NO SWITCH

SIZE X	PART NO. SCC-08-SG-HC	REV. A
REF: S00009T	SCALE: NTS	SHEET 1 OF 1

6

5

4

3

2

1