

Rev	AWO #	Description	Date	Appr
-		RELEASED	2/16/06	

APPROVED: _____ TITLE: _____
 DATE: _____

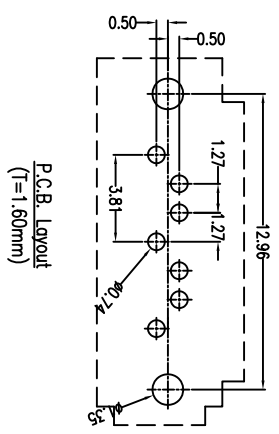
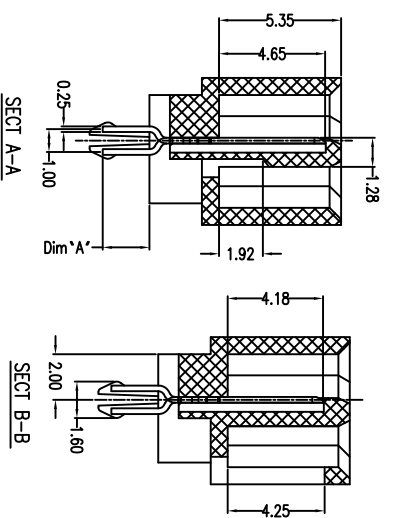
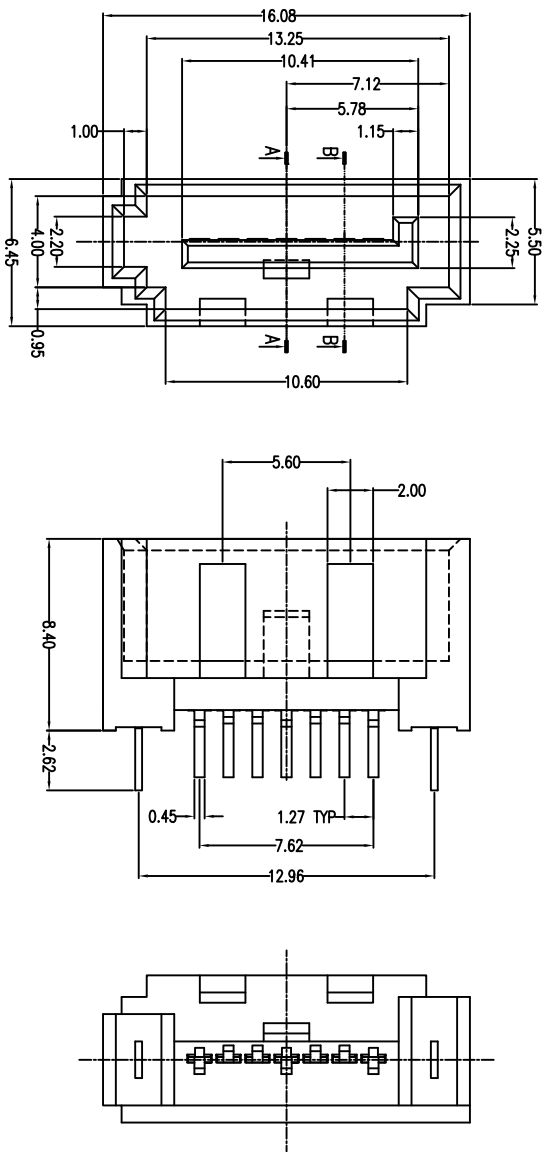

SPECIFICATIONS:

- Material: Insulator: LCP, rated UL 94V-0
- Insulator color: Black
- Contacts: Brass
- Shell: Steel, Nickel plated
- Plating: Gold flush over Nickel underplate on mating area, Tin over Copper underplate on tails
- Electrical:
 - Operating voltage: 30 VAC max
 - Current rating: 1.5 Amps max
 - Contact resistance: 30 mohms max
 - Insulation resistance: 1,000 Mohms min @ 500 VAC
 - Dielectric withstanding voltage: 500 VAC for 1 minute
- Mechanical:
 - Insertion force: 45N max.
 - Withdrawal force: 10N min.
 - Durability: 500 cycles
 - Temperature Rating: Operating temperature: -55°C to +125°C
 - Environmental: Lead free, RoHS compliant
 - Recommended soldering temp: 260°C for 5 seconds



ADAM TECH

909 Railway Avenue, Union, NJ 07083
 Phone: 908-687-5000 Fax: 908-687-5710

TITLE: SERIAL ATA CONNECTOR, TYPE A
 LEFT POLARIZATION, VERTICAL, KEYED

UNLESS OTHERWISE SPECIFIED ALL DIMENSIONS ARE INCHES [MM]		TOLERANCES ARE NOTED INCHES		Holes	
.X	± .10	ØXX	± .10		
.XX	± .020	ØXXX	± .015		
.XXX	± .015	ØXXXX	± .010		
APPROVALS	DATE				
DRAWN	SS	2/16/06			
CHECKED					
APPROVED					
REF:	SIZE	PART NO.	SCALE:	SHEET	REV.
	X	SATAA-PL-VT-K	NTS	1 OF 1	