

Rev	AWO #	Description	Date	Appr
-		RELEASED	9/10/10	

APPROVED: _____
 DATE: _____ TITLE: _____

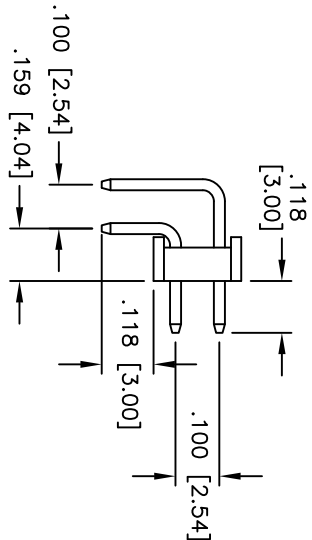
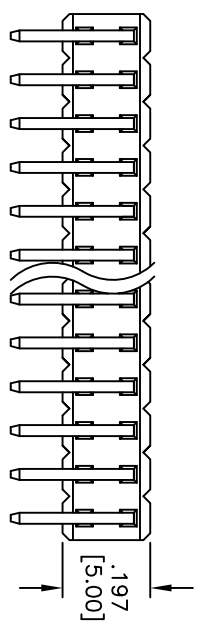
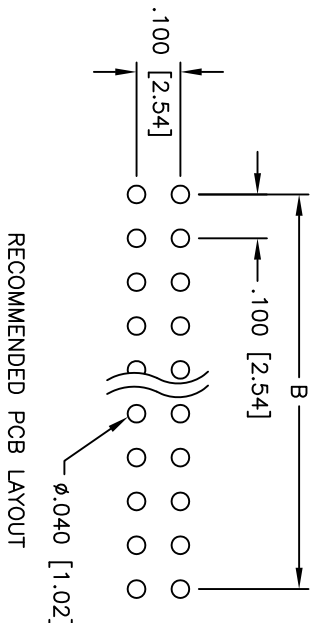
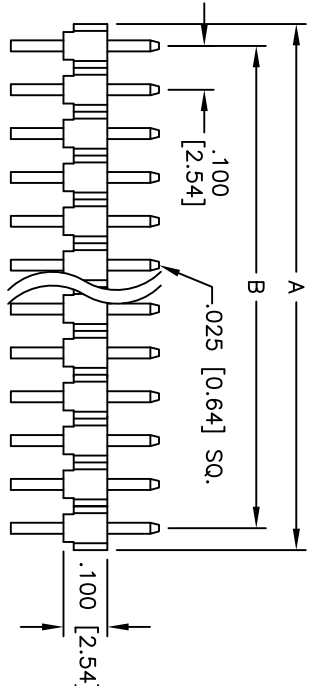

SPECIFICATIONS:

Material: Hi-temp thermoplastic, rated UL 94V-0
 Insulator color: Black
 Contacts: Brass

Plating: Gold flash over Nickel underplate overall

Electrical:

Current rating: 3 Amps max
 Contact resistance: 20 mohms max
 Insulation resistance: 1,000 Mohms min
 Dielectric withstanding voltage: 600 VAC for 1 minute
 Temperature Rating: -40°C to +105°C



Operating temperature: -40°C to +105°C
 Environmental: Lead free, RoHS compliant
 Recommended soldering temp: 260°C for 5 seconds

Positions: 4 thru 80
 A = .100 [2.54] x No. of Positions per Row
 B = .100 [2.54] x No. of Spaces

UNLESS OTHERWISE SPECIFIED
 ALL DIMENSIONS ARE IN INCHES [MM]
 TOLERANCES: EXCEPT AS NOTED
 INCHES: .X ± .10, .XX ± .020, .XXX ± .015
 HOLE SIZES: ØX ± .10, ØXX ± .015, ØXXX ± .010

DRAWN	DY	9/10/10
CHECKED		
APPROVED		

ADAM TECH
 909 Rahway Avenue, Union, NJ 07083
 Phone: 908-687-5000 Fax: 908-687-5710

TITLE: .100 [2.54] DUAL ROW PIN HEADER
 RIGHT ANGLE, GOLD PLATED

SIZE	PART NO.	REV.
X	PH2RA-XX-U-.118/.118/.159-HT	-
REF: S00032T	SCALE: NTS	SHEET 1 OF 1