

Rev	AWO #	Description	Date	Appr
-		RELEASED	10/15/08	

APPROVED: _____
 DATE: _____ TITLE: _____

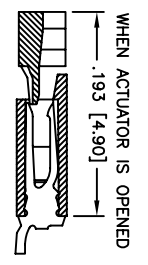
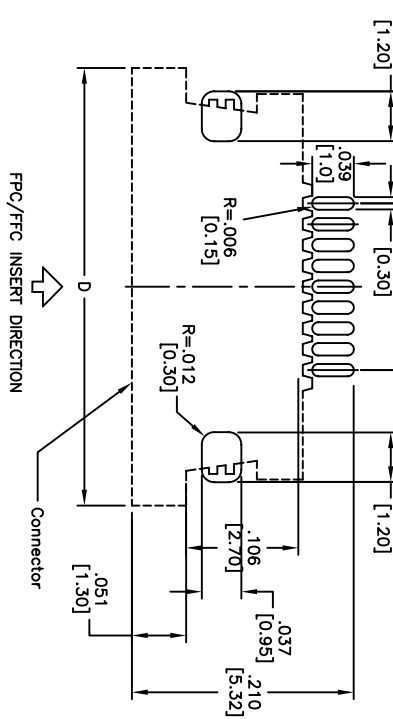
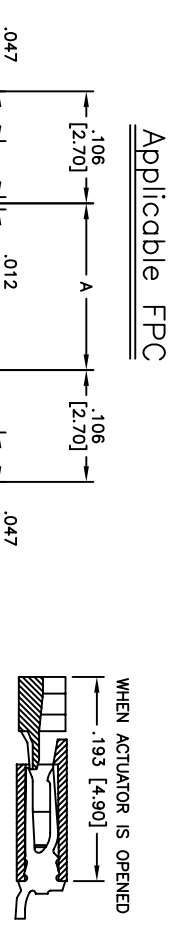
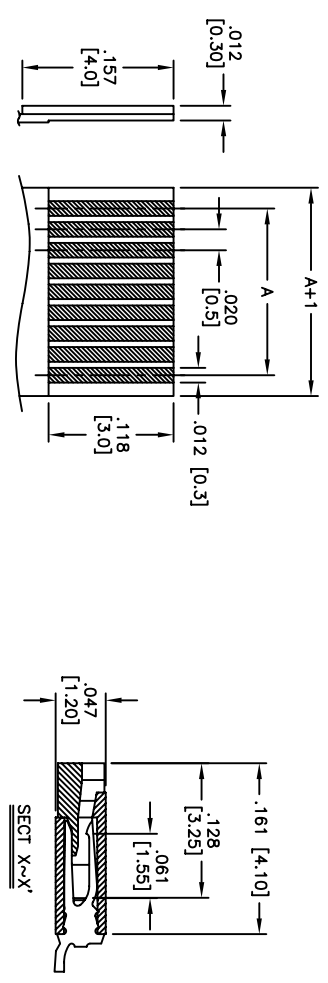
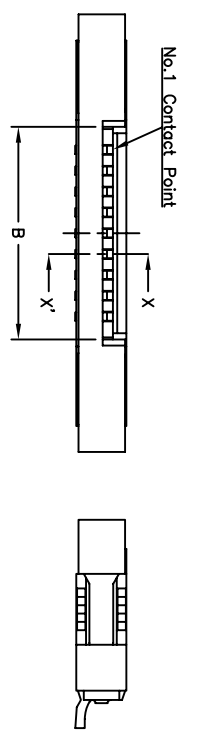
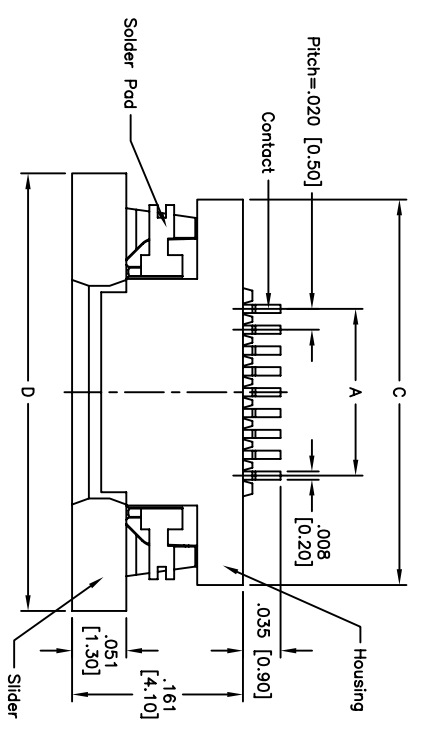

SPECIFICATIONS:
Material:
 Insulator: LCP, Glass reinforced, rated UL 94V-0
 Insulator color: Natural
 Contacts: Copper Alloy
Plating:
 Tin over Copper underplate overall
Electrical:
 Operating voltage: 50 VAC max
 Current rating: 0.4 Amps max
 Contact resistance: 30 mohms max initial
 Insulation resistance: 500 Mohms min
 Dielectric withstanding voltage: 500 VAC for 1 minute
 Operating temperature: -55°C to +85°C
 Environmental:
 Lead free, RoHS compliant.
 Recommended soldering temp: 260°C for 5 sec.

PCB Layout

PACKAGED ON TAPE & REEL

Positions: 4 thru 50
 A = .020 [0.50] x No. of Spaces
 B = A + .043 [1.10]
 C = A + .207 [5.25]
 D = A + .256 [6.50]



UNLESS OTHERWISE SPECIFIED ALL DIMENSIONS ARE INCHES [MM]	
TOLERANCES: EXCEPT AS NOTED	
INCHES	HOLDS
.X ± .10	ØX ± .10
.XX ± .020	ØXX ± .015
.XXX ± .015	ØXXX ± .010
APPROVALS	
DRAWN	DATE
CHECKED	
APPROVED	

ADAM TECH
 909 Railway Avenue, Union, NJ 07083
 Phone: 908-687-5000 Fax: 908-687-5710

TITLE		ZIF FLEX CIRCUIT CONNECTOR	
SIDE ENTRY, UPPER CONTACT, SMT		PCA-6B-XX-HU-3-T/R	
SIZE	PART NO.	SCALE	SHEET 1 OF 1
X		NTS	
REV.			