

Rev	AWO #	Description	Date	Appr
		SEE SHT 1 OF 2 FOR REVISION		

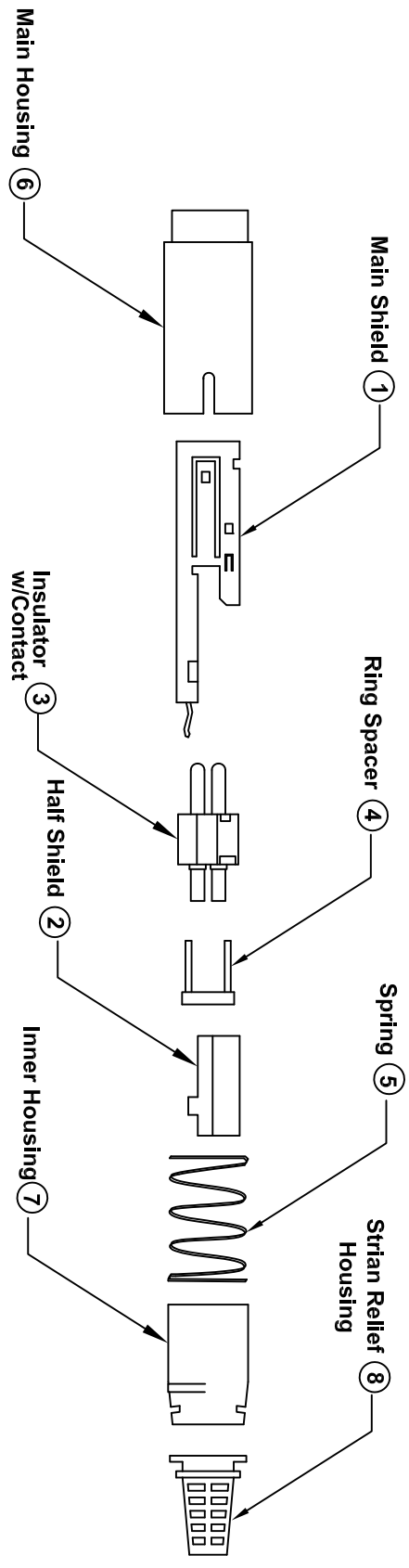

Cable Shield

Assembly Instructions:

- 1- Place Strain Relief Housing (8) and Inner Housing (7), over the cable (small diameter away from connector).
- 2- Strip and Trim Wires in Cable.
- 3- Solder Wires to Insulator (3) Solder Cups.
- 4- Insert Insulator into Main Shield (1) Orienting Slots in Insulator to Keys in Shield. Push Insulator Forward till it Locks in Place in Main Shield.
- 5- Slide Ring Spacer (4) Over Rear of Shield and then into Slots on Rear of Insulator, Push Complete Assembly Forward so Ring Spacer Fits Over the Outside Diameter of Shield.
- 6- Place Half Shield (2) onto the Indented Portions of the Rear of the Main Shield.

NOTE: Tapered Lead-in on both Main Half Shields should be lined up at Rear Edge.

- 7- Place Spring (5) Over Both Shields while Holding them in place.
- 8- Line up the Assembled Shield with the Inner Housing (7), which is already on Cable. The Larger Diameter or the Housing could Slip Over the Shield Assembly. Press till both Parts Lock in Place.
- 9- Slide the Strain Relief Housing (already on Cable) up the Inner Housing and then Slip the Notches on Strain Relief under the Slots on Inner Housing.
- 10- Finally, Slide the Main Housing (6) Over the Front of the Connector Assembly and Lock in Place.

Environmental:
Lead free, RoHS compliant.



UNLESS OTHERWISE SPECIFIED ALL DIMENSIONS ARE IN INCHES [MM]	
TOLERANCES: EXCEPT AS NOTED	HOLDS
.X ± .10	∅XX ± .10
.XX ± .020	∅XXX ± .015
.XXX ± .015	∅XXXX ± .010
APPROVALS	DATE
DRAWN	SS
CHECKED	
APPROVED	

ADAM TECH
909 Rahway Avenue, Union, NJ 07083
Phone: 908-687-5000 Fax: 908-687-5710

TITLE: ASSEMBLY INSTRUCTIONS
FOR MP SERIES

SIZE	PART NO.	SCALE	SHEET
X	MP-XX-D	NTS	2 OF 2
REV.	B		