

Rev	AWO #	Description	Date	Appr
-		RELEASED	6/04/10	

APPROVED: _____
 DATE: _____ TITLE: _____

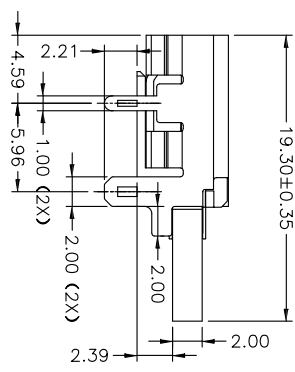
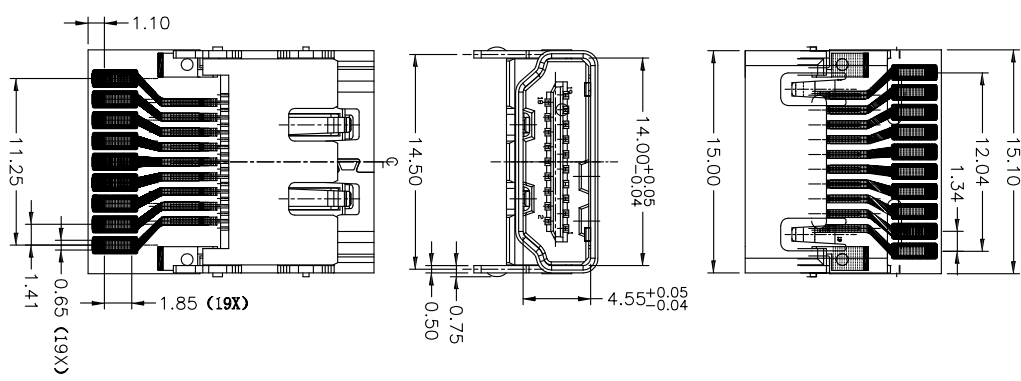
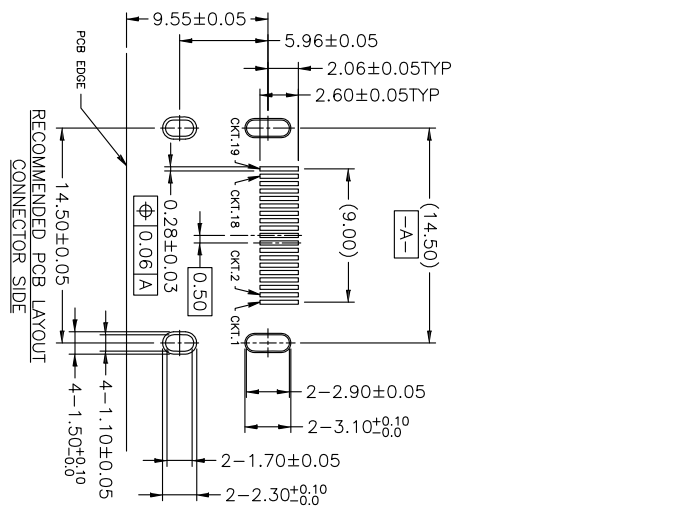

SPECIFICATIONS:

- Material:** Housing: Hi-temp thermoplastic, UL 94V-0
- Housing color: Black
- Contact: Copper Alloy
- Shield: Copper Alloy, Nickel plated
- Plating:** Gold flash over Nickel underplate on contact area, Tin over Copper underplate on tails.
- Electrical:** Voltage rating: 40V
- Current rating: 0.5A
- Dielectric strength: 300VAC for 1 minute min.
- Insulation resistance: 100 Megohm min.
- Contact resistance: 10 mohms max.
- Environmental:** Lead free, RoHS Compliant
- Recommended soldering temp: 260°C for 5 seconds.

A

6

5

4

3

2

1

ADAM TECH

909 Rahway Avenue, Union, NJ 07083
 Phone: 908-687-5000 Fax: 908-687-5710

HDMI CONNECTOR, RIGHT ANGLE, SMT

UNLESS OTHERWISE SPECIFIED ALL DIMENSIONS ARE IN MM	
TOLERANCES: EXCEPT AS NOTED	
INCHES	HOLES
.X ± .10	ØX ± .10
.XX ± .020	ØXXX ± .015
.XXX ± .015	ØXXX ± .010
APPROVALS	DATE
DRAWN DY	6/04/10
CHECKED	
APPROVED	

SIZE	PART NO.	REV.
X	HDMI-S-RA-SMT-FLEX	-
REF:	S00015C	
SCALE:	NTS	
SHEET	1 OF 1	

