

6

5

4

3

2

1

Rev	AWO #	Description	Date	Appr
-		RELEASED	1/16/06	

APPROVED: \_\_\_\_\_

DATE: \_\_\_\_\_ TITLE: \_\_\_\_\_

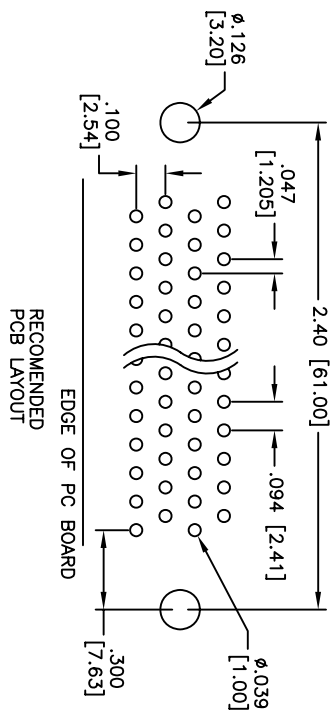
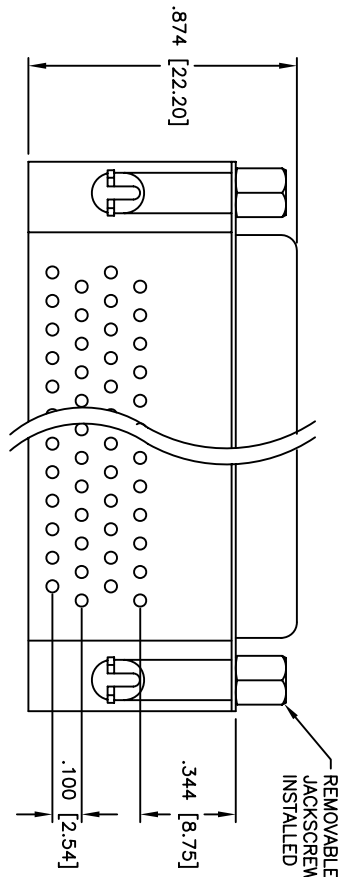
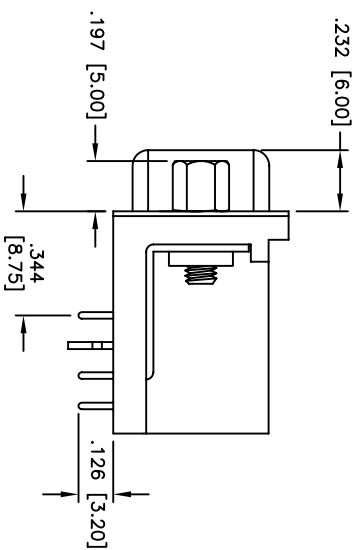
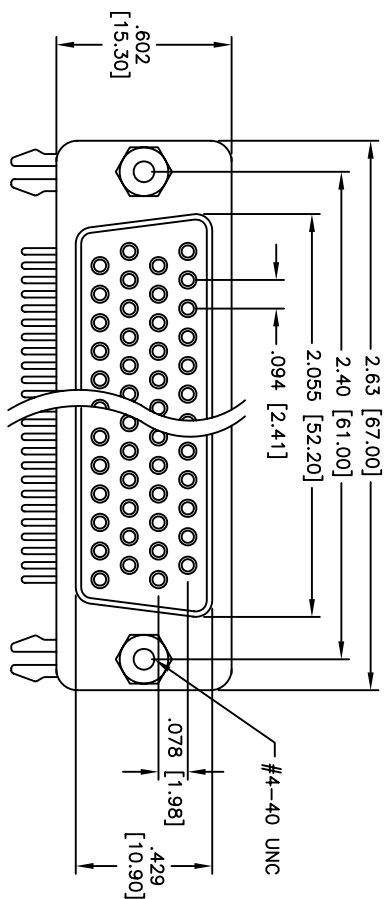

**SPECIFICATIONS:**

- Material: Insulator: PBT, glass reinforced, rated UL 94V-0
- Insulator color: Black
- Contacts: Phosphor Bronze
- Shell: Steel, Tin plated
- Hardware: Brass, Nickel plated
- Plating: Gold flash over Nickel underplate overall

- Electrical: Operating voltage: 250 VAC max
- Current rating: 5 Amps max
- Contact resistance: 20 mohms max
- Insulation resistance: 5,000 Mohms min
- Dielectric withstanding voltage: 1,000 VAC for 1 minute
- Temperature Rating: Operating temperature: -65°C to +125°C
- Environmental: Lead free, RoHS compliant
- Recommended soldering temp: 230°C for 5 seconds



**ADAM TECH**

909 Rahway Avenue, Union, NJ 07083  
 Phone: 908-687-5000 Fax: 908-687-5710

TITLE: HIGH DENSITY D-SUB SOCKET, R/A  
 #4-40 INSERTS & FORKED BOARDLOCKS

UNLESS OTHERWISE SPECIFIED ALL DIMENSIONS ARE INCHES [MM] TOLERANCES: EXCEPT AS NOTED INCHES		DRAWN		DATE	
.X ± .10	ØX ± .10	SS	1/16/06		
.XX ± .020	ØXX ± .015	CHECKED			
.XXX ± .015	ØXXX ± .010	APPROVED			
APPROVALS		SIZE	PART NO.	SCALE	SHEET 1 OF 1
		X	HDL78-SL-C	NTS	
		REF:			

6

5

4

3

2

1