

| Rev | AWO # | Description | Date | Appr |
|-----|-------|-------------|----------|------|
| - | | RELEASED | 10/23/08 | |

APPROVED: _____
 DATE: _____ TITLE: _____

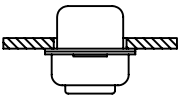

REAR MOUNTING

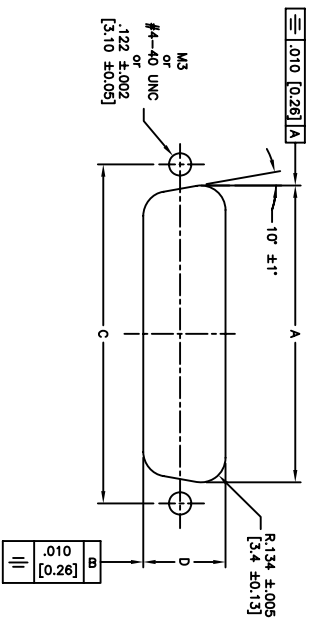
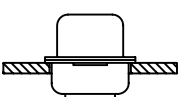
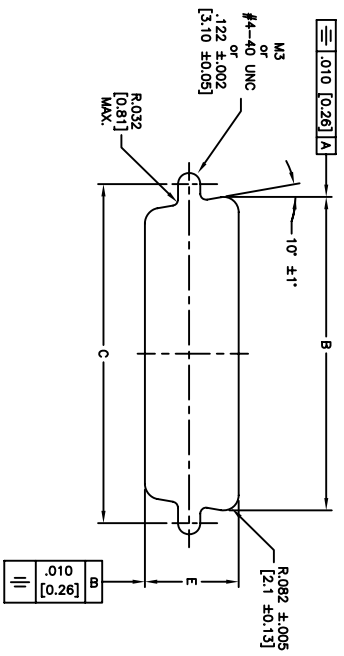

FRONT MOUNTED

| Positions | DIMENSIONS (All Dimensions ±.005 [0.13]) | | | | |
|-----------|--|---------------|---------------|--------------|--------------|
| | A | B | C | D | E |
| 9 | .807 [20.50] | .874 [22.20] | .984 [25.00] | .449 [11.44] | .513 [13.03] |
| 15 | 1.134 [28.80] | 1.200 [30.50] | 1.312 [33.32] | .449 [11.44] | .513 [13.03] |
| 25 | 1.673 [42.50] | 1.744 [44.30] | 1.852 [47.04] | .449 [11.44] | .513 [13.03] |
| 37 | 2.326 [59.10] | 2.389 [60.70] | 2.500 [63.50] | .449 [11.44] | .513 [13.03] |
| 50 | 2.216 [56.30] | 2.295 [58.30] | 2.405 [61.10] | .555 [14.10] | .623 [15.82] |

Unit: Inch / mm

UNLESS OTHERWISE SPECIFIED
 ALL DIMENSIONS ARE INCHES [MM]
 TOLERANCES: EXCEPT AS NOTED
 INCHES HOLE SIZES
 .X ±.10 ØXX ±.10
 .XX ±.020 ØXXX ±.015
 .XXX ±.015 ØXXXX ±.010
 APPROVALS DATE

ADAM TECH
 909 Rahway Avenue, Union, NJ 07083
 Phone: 908-687-5000 Fax: 908-687-5710
 D-SUB PANEL CUT-OUT, MALE/FEMALE,
 9, 15, 25, 37 & 50 POSITION
 DRAWN SS 10/23/08
 CHECKED X
 APPROVED X
 TITLE: D-SUB PANEL CUT-OUT, MALE/FEMALE,
 9, 15, 25, 37 & 50 POSITION
 SIZE: PART NO.: DXXX+PANEL CUTOUT
 REF: SCALE: NTS SHEET 1 OF 1