

| Rev | AWO # | Description | Date    | Appr |
|-----|-------|-------------|---------|------|
| -   |       | RELEASED    | 1/19/11 |      |

APPROVED: \_\_\_\_\_  
 DATE: \_\_\_\_\_ TITLE: \_\_\_\_\_

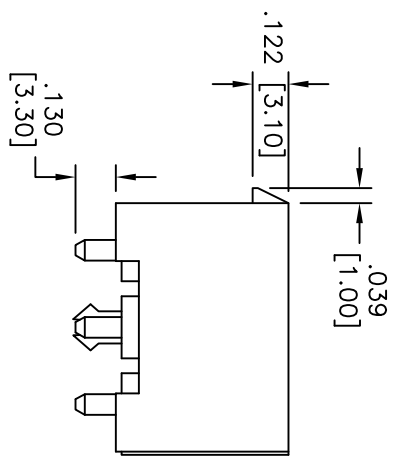
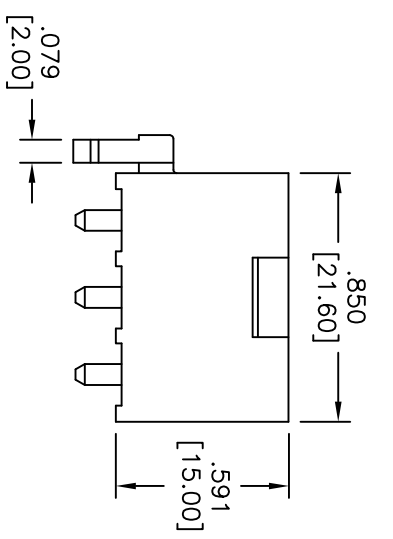
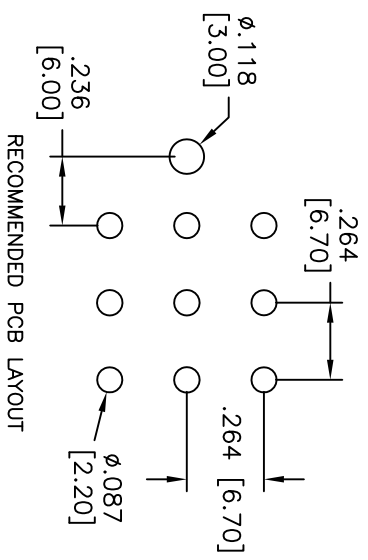
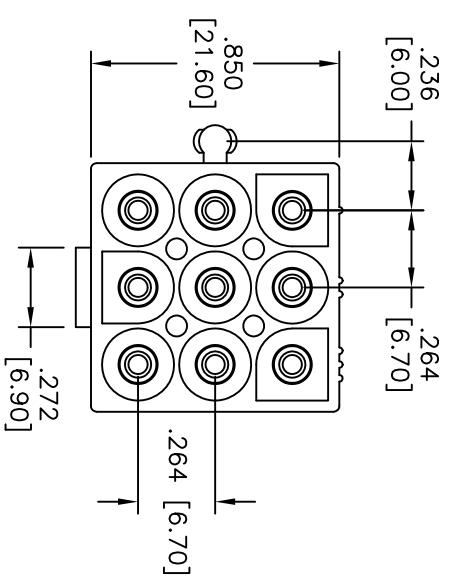

**SPECIFICATIONS:**

**Material:**  
 Insulator: Nylon66, rated UL94V-2  
 Insulator color: Natural  
 Contact: Brass, Tin plated

**Electrical:**  
 Current rating: 8A AC, DC  
 Voltage rating: 600V AC, DC  
 Dielectric withstanding voltage: 5000V AC rms  
 Ambient temperature range: -40°C to +105°C

**Environmental:**  
 Lead free, RoHS compliant.  
 Recommended soldering temp: 235°C for 5 sec.

**ADAM TECH**

909 Rahway Avenue, Union, NJ 07083  
 Phone: 908-687-5000 Fax: 908-687-5710

9 POLES, SQUARE TYPE

|  |             |
|--|-------------|
| UNLESS OTHERWISE SPECIFIED<br>ALL DIMENSIONS ARE INCHES [MM] |             |
| TOLERANCES: EXCEPT AS NOTED                                  |             |
| INCHES   | HOLDS       |
| .X ± .10   | ØX ± .10    |
| .XX ± .020   | ØXX ± .015  |
| .XXX ± .015  | ØXXX ± .010 |
| APPROVALS  | DATE        |
| DRAWN  | DY          |
| CHECKED  | 1/19/11     |
| APPROVED   |             |

|                                   |      |             |       |        |
|-----------------------------------|------|-------------|-------|--------|
| TITLE                             |      | PART NO.    |       | REV.   |
| .264 [6.70] WIRE TO BOARD, A TYPE |      | DME-A-09-SQ |       | -      |
| REF:                              | SIZE | SCALE:      | SHEET | 1 OF 1 |
| S00123T                           | X    | NTS         | 1     |        |