

APPROVED: \_\_\_\_\_  
 DATE: \_\_\_\_\_ TITLE: \_\_\_\_\_

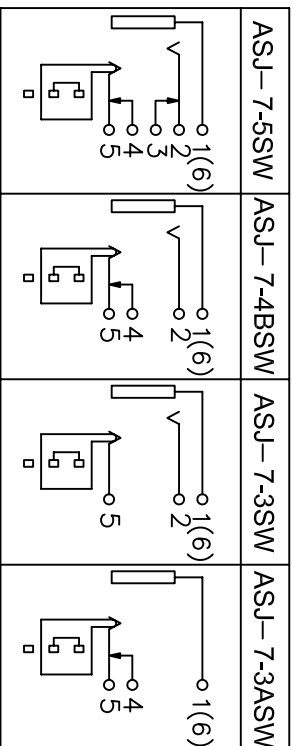

**SPECIFICATIONS:**

Material: Insulator: PA66, rated UL 94V-0  
 Insulator color: Black  
 Contacts: Phosphor Bronze  
 Plating: Silver over Nickel underplate overall  
 Electrical:  
 Operating voltage: 250 VAC max  
 Current rating: 0.5 Amp max  
 Contact resistance: 30 mohms max  
 Insulation resistance: 1,000 Mohms min  
 Dielectric withstanding voltage: 500 VAC for 1 minute  
 Temperature Rating:  
 Operating temperature: -65°C to +125°C  
 Environmental:  
 Lead free, RoHS compliant  
 Recommended soldering temp: 235°C for 5 seconds

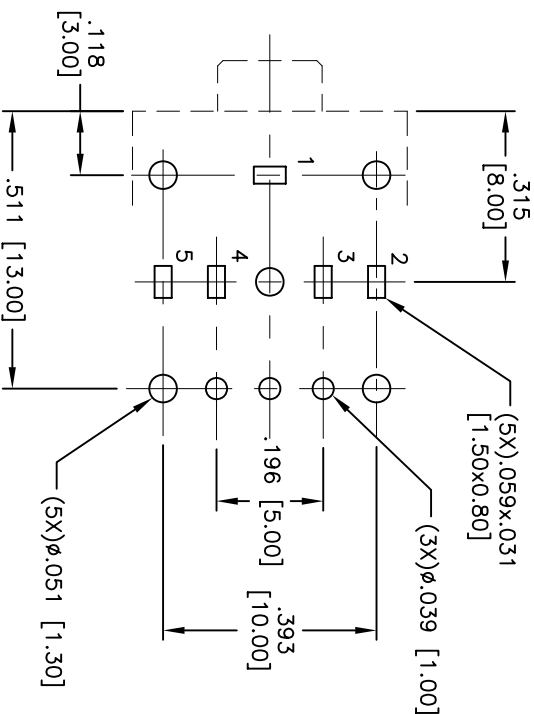
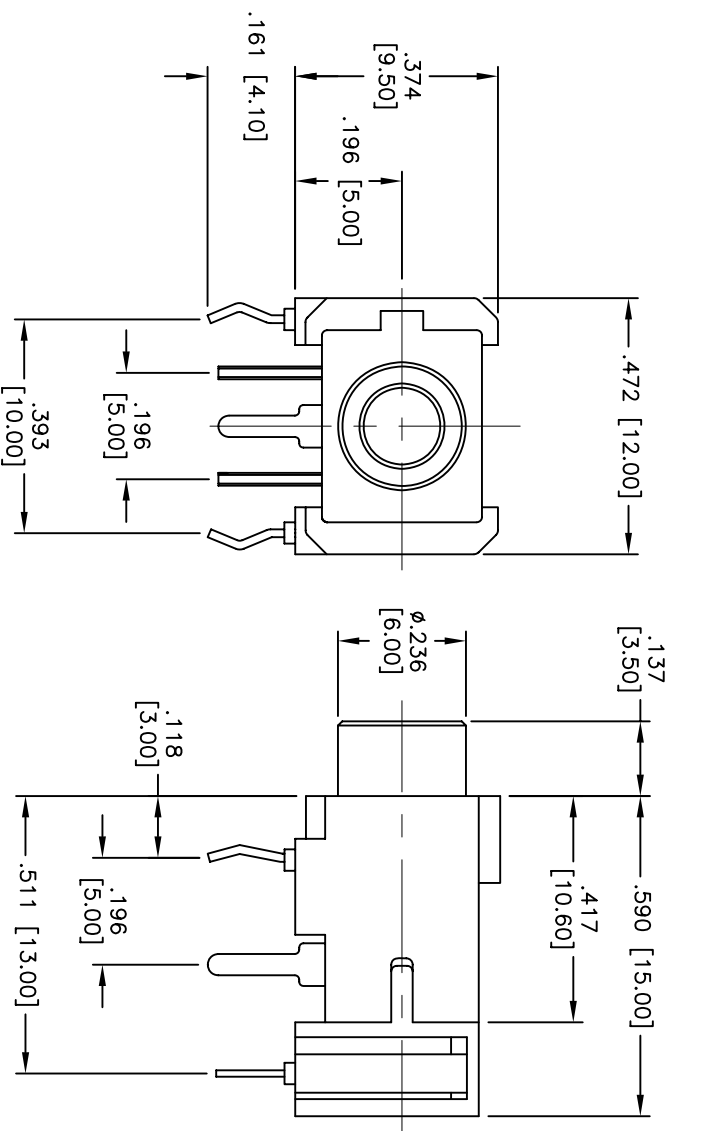

UNLESS OTHERWISE SPECIFIED  
 ALL DIMENSIONS ARE IN INCHES [MM]  
 TOLERANCES: EXCEPT AS NOTED  
 INCHES  
 .X ± .10  
 .XX ± .020  
 .XXX ± .015  
 .XXX ± .015  
 HOLE SIZES  
 $\phi$ X ± .10  
 $\phi$ XXX ± .015  
 $\phi$ XXX ± .010

**APPROVALS**

DRAWN	BW	12/06/06
CHECKED		
APPROVED		

TITLE: PHONE JACK, 3.6mm

909 Railway Avenue, Union, NJ 07083  
 Phone: 908-687-5000 Fax: 908-687-5710

**ADAM TECH**

SIZE	PART NO.	REV.
X	ASJ-7-XSW	A
REF:	SCALE: NTS	SHEET 1 OF 1