

APPROVED: \_\_\_\_\_  
 DATE: \_\_\_\_\_ TITLE: \_\_\_\_\_

Rev	AWO #	Description	Date	Appr
-		RELEASED	04/05/05	
B		ADDED SCHEMATICS	11/10/06	
C		REDRAWN	11/22/10	

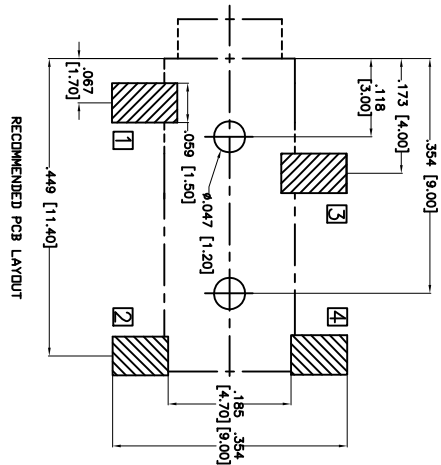
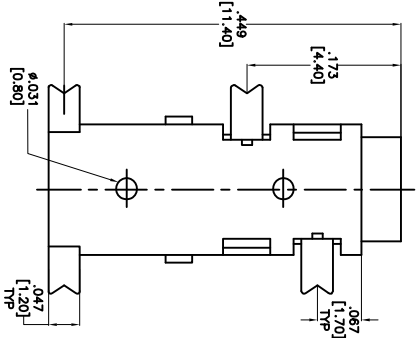
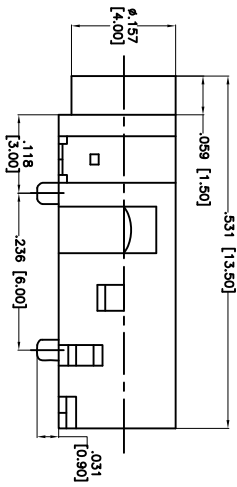
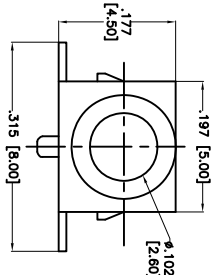

CONTACT FORM	ASJ-48-3	ASJ-48-3A	ASJ-48-4B
SCHEMATIC			

**SPECIFICATIONS:**  
 Material: Silver over Nickel underplate overall  
 Insulator: Hi-Temp Thermoplastic, rated UL 94V-0  
 Contacts: Copper Alloy  
 Plating:  
 Silver over Nickel underplate overall  
**Electrical:**  
 Operating voltage: 30 VDC max.  
 Current rating: 0.5 Amp max.  
 Contact resistance: 30 mohms max. initial  
 Insulation resistance: 100 Mohms min.  
 Dielectric withstanding voltage: 500 VAC for 1 minute  
 Temperature Rating:  
 Operating temperature: -20°C to +70°C  
**Environmental:**  
 Lead free, RoHS compliant.  
 Recommended soldering temp: 260°C for 5 sec.

UNLESS OTHERWISE SPECIFIED  
 ALL DIMENSIONS ARE INCHES [MM]  
 TOLERANCES: EXCEPT AS NOTED  
 INCHES Holes  
 .X ± .10 ØX ± .10  
 .XX ± .020 ØXX ± .015  
 .XXX ± .015 ØXXX ± .010  
 APPROVALS DATE

**ADAM TECH**  
 909 Rahway Avenue, Union, NJ 07083  
 Phone: 908-687-5000 Fax: 908-687-5710  
**STEREO JACK, 2.5MM, PANEL MOUNT**

DRAWN	SS	04/05/05
CHECKED		
APPROVED		

SIZE	PART NO.	REV.
X	ASJ-48-X	C
REF:	S0002C	SCALE: NTS
SHEET	1 OF 1	