

Rev	AWO #	Description	Date	Appr
-		RELEASED	8/02/10	

APPROVED: \_\_\_\_\_  
 DATE: \_\_\_\_\_ TITLE: \_\_\_\_\_

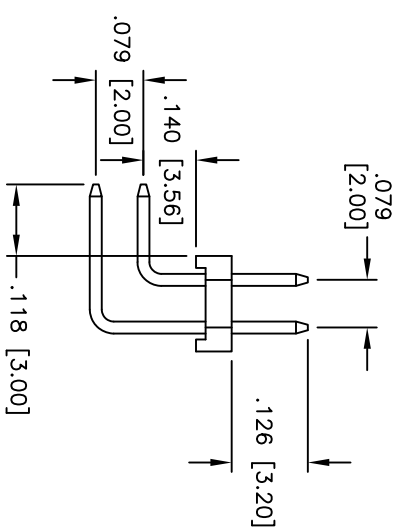
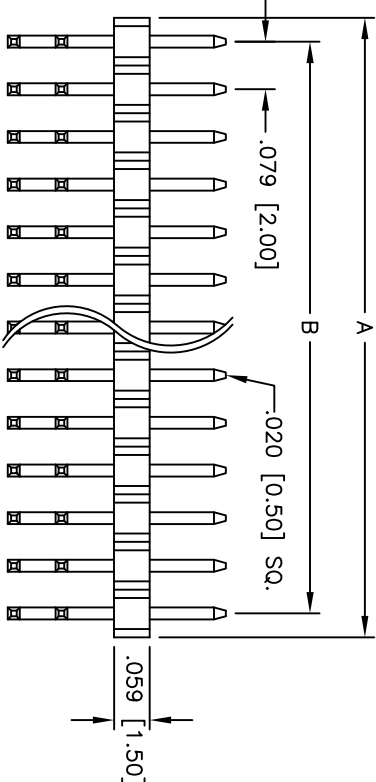
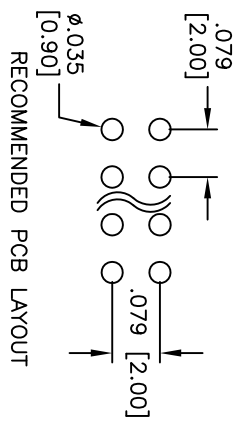
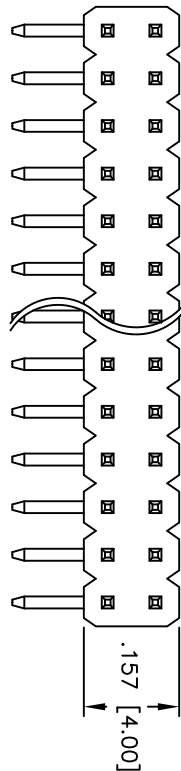

Positions: 2 thru 40 per row  
 A = .079 [2.00] x No. of Positions per row  
 B = .079 [2.00] x No. of Spaces

**SPECIFICATIONS:**  
 Material: Insulator: Hi-temp Nylon, rated UL 94V-0  
 Insulator color: Black  
 Contacts: Phosphor Bronze  
 Plating: 10u" Gold over Nickel underplate overall

**Electrical:**  
 Current rating: 2 Amp max  
 Contact resistance: 20 mohms max  
 Insulation resistance: 1,000 Mohms min  
 Dielectric withstanding voltage: 500 VAC for 1 minute  
 Temperature Rating:  
 Operating temperature: -40°C to +105°C  
 Environmental:  
 Lead free, RoHS compliant  
 Recommended soldering temp: 260°C for 5 seconds



UNLESS OTHERWISE SPECIFIED  
 ALL DIMENSIONS ARE INCHES [MM]  
 TOLERANCES: EXCEPT AS NOTED

INCHES	HOLES
.X ± .10	ØX ± .10
.XX ± .020	ØXX ± .015
.XXX ± .015	ØXXX ± .010

APPROVALS

DATE	DATE

DRAWN: DY 8/02/10  
 CHECKED: \_\_\_\_\_  
 APPROVED: \_\_\_\_\_

**ADAM TECH**  
 909 Rahway Avenue, Union, NJ 07083  
 Phone: 908-687-5000 Fax: 908-687-5710

SIZE	PART NO.	REV.
X	2PH2RB-XX-U-.126/118/140-10-HT	-

TITLE: .079 [2.00] DUAL ROW PIN HEADER  
 RIGHT ANGLE, 10u" GOLD PLATED

REF: S00032T SCALE: NTS SHEET 1 OF 1