

ORDERING INFORMATION GANGED JACKS WITHOUT LEDs

MTJG	2	64	2	2	1
SERIES INDICATOR MTJG = Ganged Telephone Jack	NO. OF PORTS 2 thru 16	PORT SIZE / POSITIONS FILLED 64 = 6 position, 4 contacts (6P4C) 66 = 6 position, 6 contacts (6P6C) 88 = 8 position, 8 contacts (8P8C)	CONTACT PLATING X = Gold flash 0 = 15 μ in. gold 1 = 30 μ in. gold 2 = 50 μ in. gold	HOUSING TYPE 2, 2B, 2C, 5, 7H, 7V, AR, C, G, J, N	HOUSING COLOR 1 = Black 2 = Medium Gray (Housing Type 7 only)

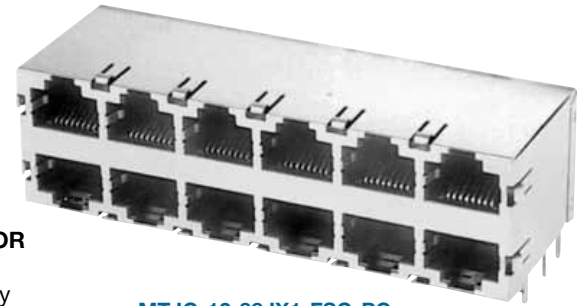

MTJG-12-88JX1-FSG-PG

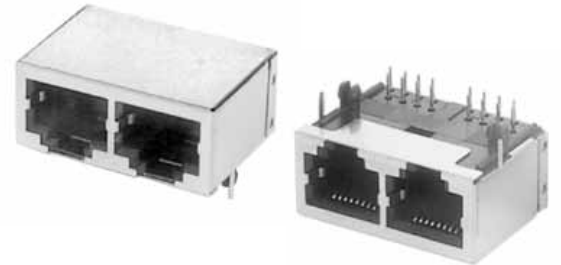

MTJG-2-88GX1-FSG

ORDERING INFORMATION GANGED JACKS WITH LEDs

MTJG	2	64	AR	2	1	LD
SERIES INDICATOR MTJG = Ganged Telephone Jack	NO. OF PORTS 2, 4, 6, 8, 12 or 16	PORT SIZE / POSITIONS FILLED 62 = 6 position, 2 contacts (6P2C) 64 = 6 position, 4 contacts (6P4C) 66 = 6 position, 6 contacts (6P6C) 88 = 8 position, 8 contacts (8P8C)	HOUSING TYPE AR, G, J	CONTACT PLATING X = Gold flash 0 = 15 μ in. gold 1 = 30 μ in. gold 2 = 50 μ in. gold	HOUSING COLOR 1 = Black	LED CONFIGURATION See Chart Below



MTJG-4-88ARX1-FSM-PG-LG

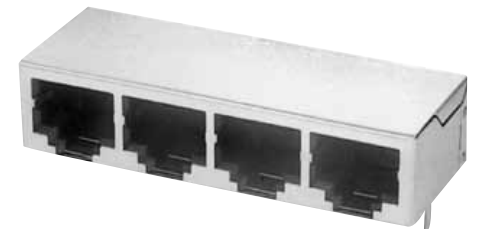

MTJG-4-88GX1-FSB

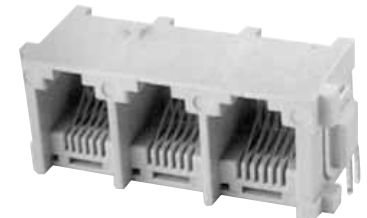

MTJG-3-667HX2

OPTIONS:

Add as suffix to basic part no.

FSX = Full metal shield

PG = Panel ground tabs

SMT = Surface mount tails with Hi-Temp insulation for hi-temp soldering processes up to 260°C

Add suffix to end of P/N:

LED CONFIGURATION		
SUFFIX	LED 1	LED 2
LA	YELLOW	YELLOW
LD	GREEN	GREEN
LG	YELLOW	GREEN
LH	GREEN	YELLOW
LI	ORANGE/ GREEN	ORANGE/ GREEN



Ordering Information pg. 34

TYPE 2
6P4C
6P6C

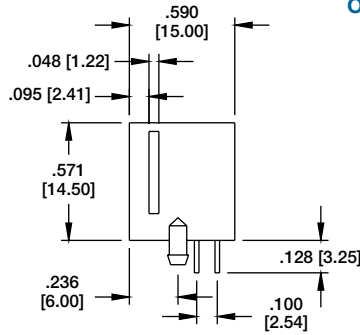
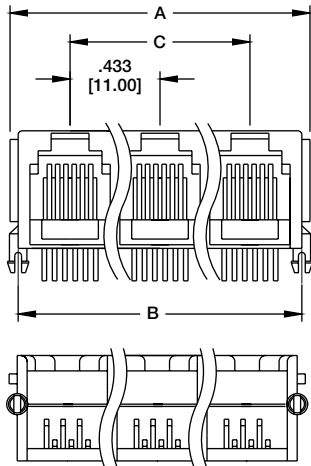

MTJG-2-642X1

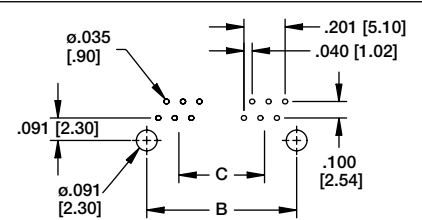

Recommended PCB Layout

A = .433 [11.00] x No. of Ports + .100 [2.54]
 B = .433 [11.00] X No of Ports + .020 [0.50]
 C = .433 [11.00] x No of Ports - 1

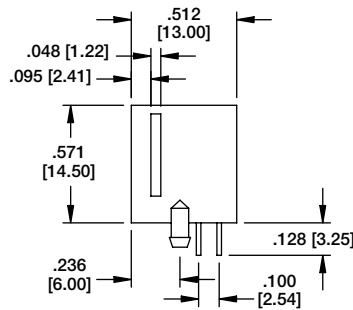
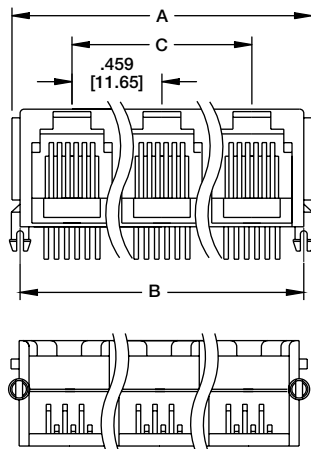

MTJG-2-642BX1

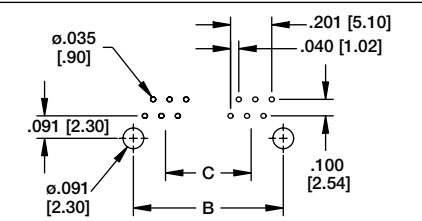

Recommended PCB Layout

A = .459 [11.65] x No. of Ports + .100 [2.54]
 B = .459 [11.65] X No of Ports + .020 [0.50]
 C = .459 [11.65] x No of Ports - 1

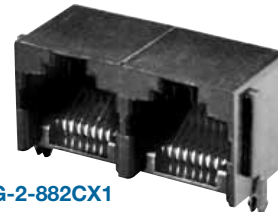
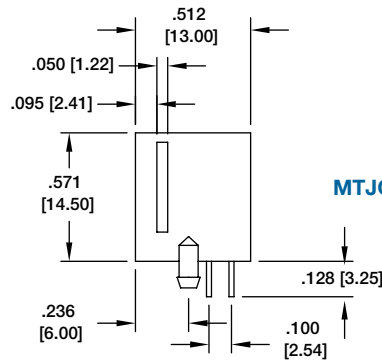
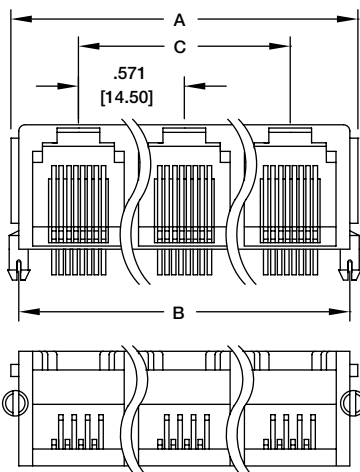

MTJG-2-882CX1

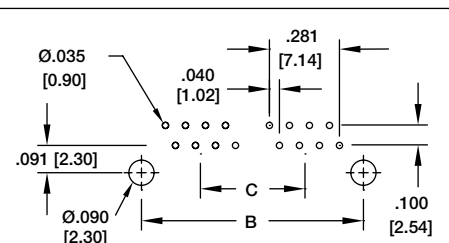

Recommended PCB Layout

A = .571 [14.50] X No. of ports + .122 [3.10]
 B = .571 [14.50] X No. of Ports + .019 [0.50]
 C = .571 [14.50] X No. of Port - 1

Ordering Information pg. 34

TYPE 7H

RIGHT ANGLE ENTRY

6P4C

6P6C

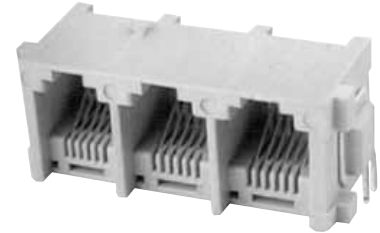

MTJG-3-667HX2

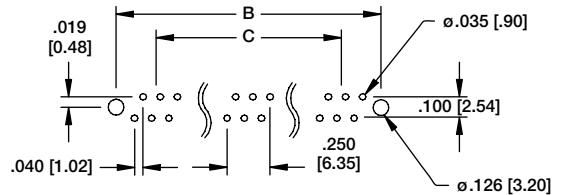
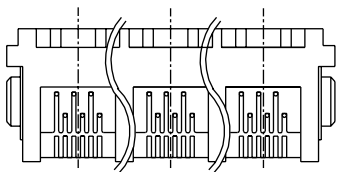
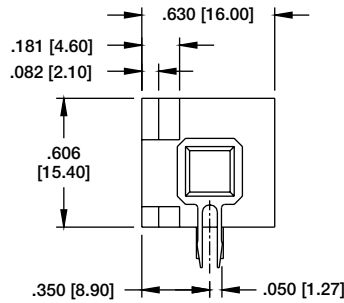
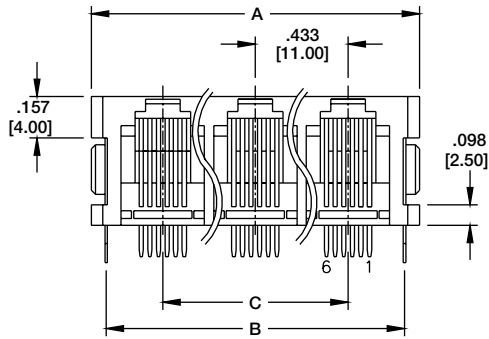

Recommended PCB Layout

TYPE 7V

TOP ENTRY

6P4C

6P6C

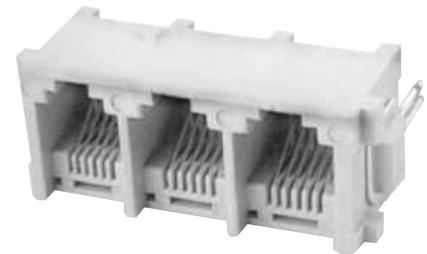

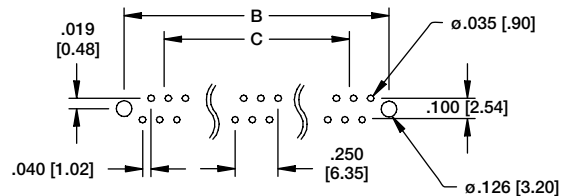
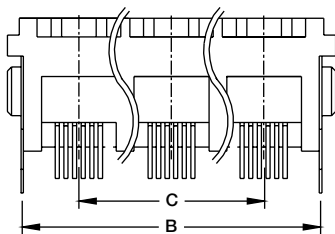
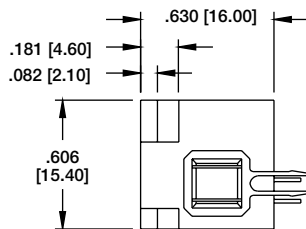
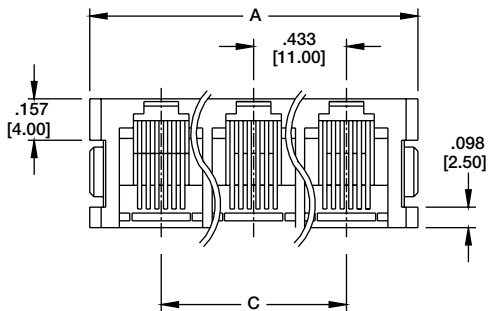

MTJG-3-667VX2

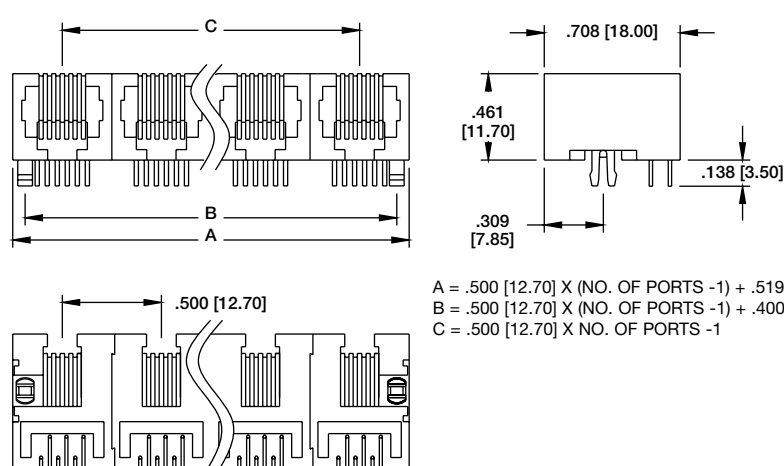
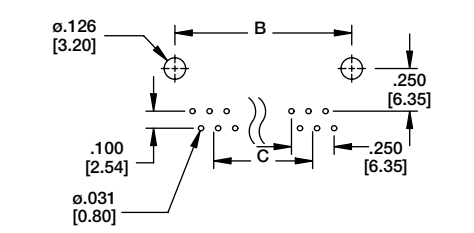
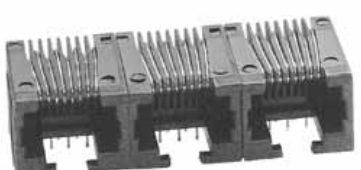
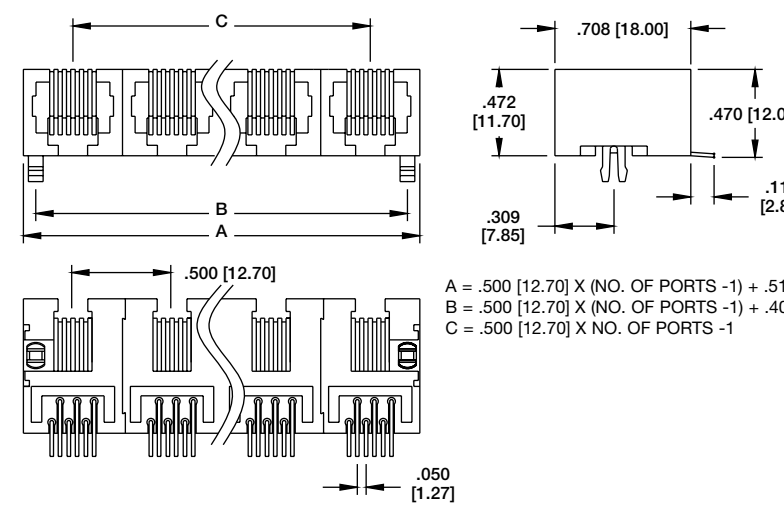
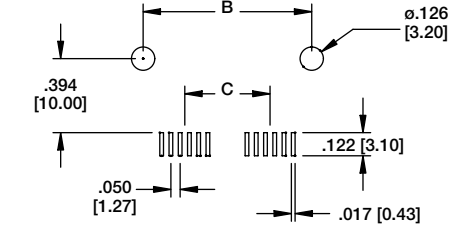
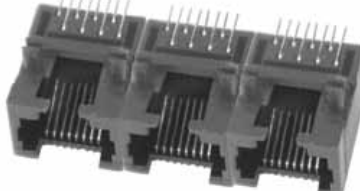
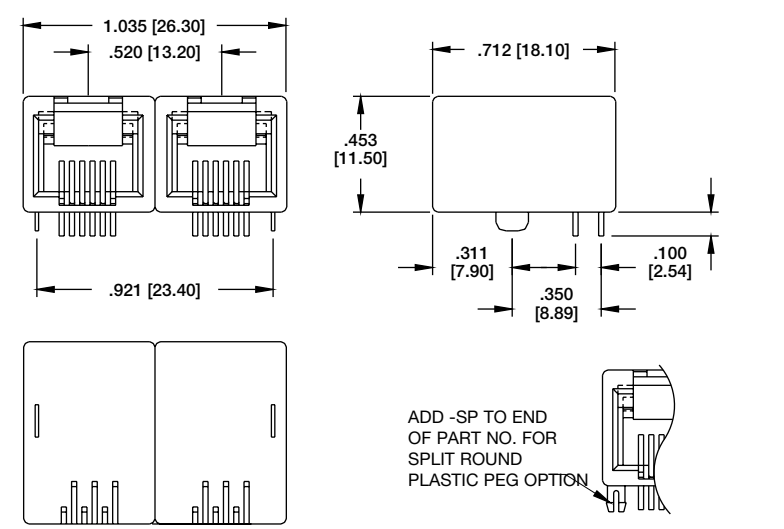
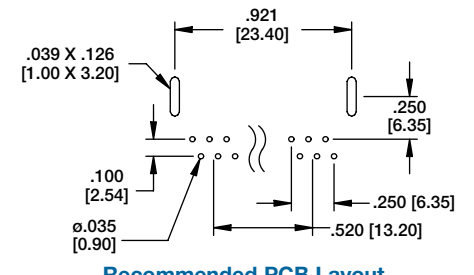

Recommended PCB Layout

DIMENSION	No of Ports						
	2	3	4	5	6	7	8
A	1.110 [28.20]	1.543 [39.20]	1.976 [50.20]	2.409 [61.20]	2.843 [72.20]	3.275 [83.20]	3.710 [94.20]
B	.992 [25.20]	1.425 [36.20]	1.858 [47.20]	2.291 [58.20]	2.724 [69.20]	3.157 [80.20]	3.590 [91.20]
C	.433 [11.00]	.886 [22.00]	1.299 [33.00]	1.732 [44.00]	2.165 [55.00]	2.598 [66.00]	3.030 [77.00]

 <p> $A = .500 [12.70] \times (\text{NO. OF PORTS} - 1) + .519 [13.20]$ $B = .500 [12.70] \times (\text{NO. OF PORTS} - 1) + .400 [10.16]$ $C = .500 [12.70] \times \text{NO. OF PORTS} - 1$ </p>	 <p>Recommended PCB Layout</p>	 <p>TYPE 5 THRU HOLE 6P4C 6P6C</p> <p>MTJG-3-665X1</p>
 <p> $A = .500 [12.70] \times (\text{NO. OF PORTS} - 1) + .519 [13.20]$ $B = .500 [12.70] \times (\text{NO. OF PORTS} - 1) + .400 [10.16]$ $C = .500 [12.70] \times \text{NO. OF PORTS} - 1$ </p>	 <p>Recommended PCB Layout</p>	 <p>TYPE 5 SMT 8P8C</p> <p>MTJG-3-885X1-SMT Available in 6P6C or 8P8C Versions</p>
 <p> ADD -SP TO END OF PART NO. FOR SPLIT ROUND PLASTIC PEG OPTION </p>	 <p>Recommended PCB Layout</p>	 <p>TYPE N METAL PEG 6P4C 6P6C</p> <p>MTJG-2-66nx1</p>

Ordering Information pg. 34

Ordering Information pg. 34

Ordering Information pg. 34

TYPE G
GANGED
8P8C

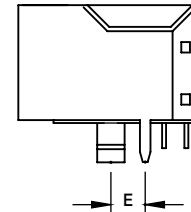
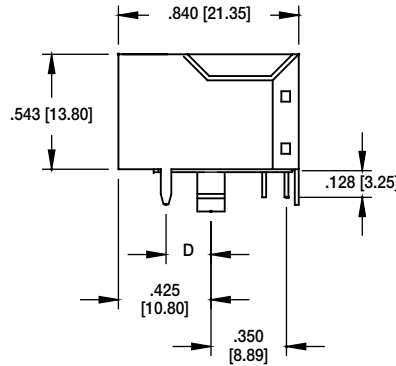
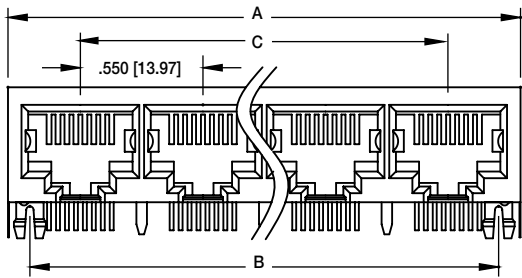

"E" DIM.
FSD = .120 [3.05]
FSR = .144 [3.65]

"D" DIM.
FSA = .170 [4.32]
FSB = .144 [3.65]
FSG = .180 [4.57]
FSE = .120 [3.05]

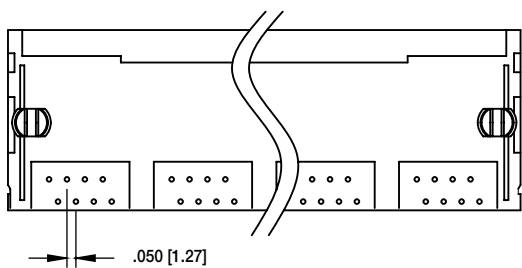

A = .550 [13.97] X (NO. OF PORTS - 1) + .679 [17.27]
B = .550 [13.97] X (NO. OF PORTS - 1) + .450 [11.43]
C = .550 [13.97] X NO. OF PORTS - 1



MTJG-4-88GX1-FSB

Recommended PCB Layout for shield ground pin locations specified as FSA, FSB, FSG & FSE

"D" DIM.
FSA = .170 [4.32] FSE = .120 [3.05]
FSB = .144 [3.65] FSG = .180 [4.57]

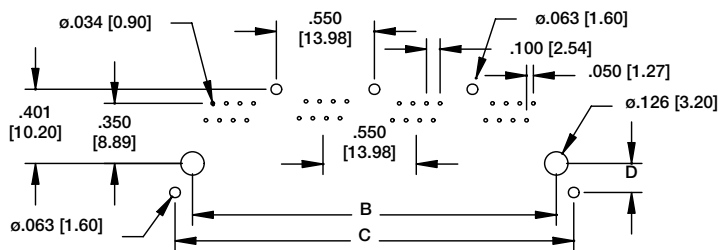

MTJG-4-88GX1-FSB-PG

Recommended PCB Layout for shield ground pin locations specified as FSD & FSR

"E" DIM.
FSD = .120 [3.05]
FSR = .144 [3.65]

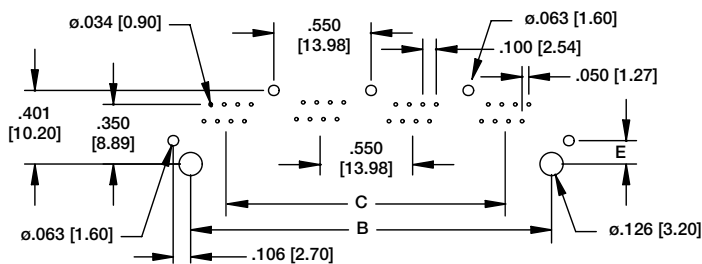

Ordering Information pg. 34

TYPE J
8P8C

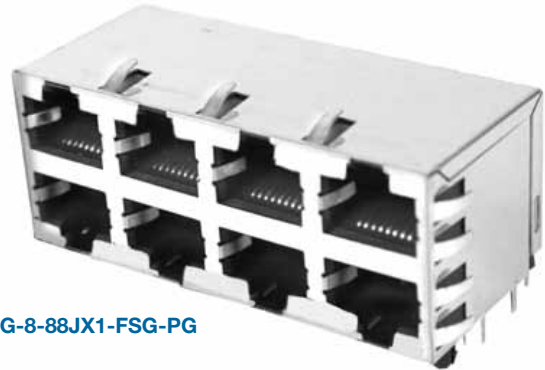
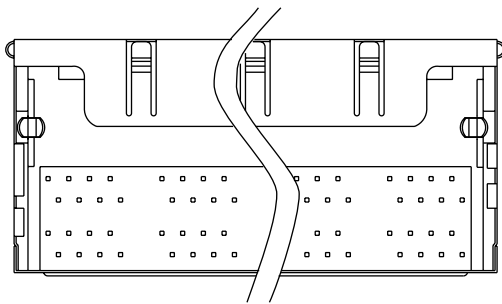
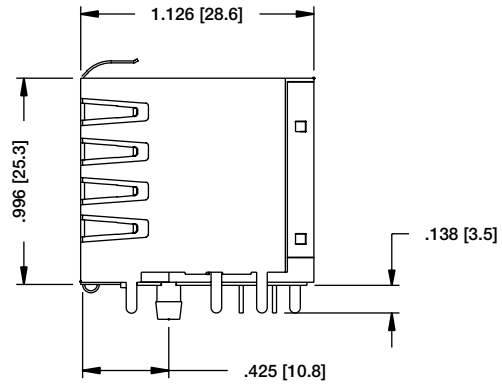
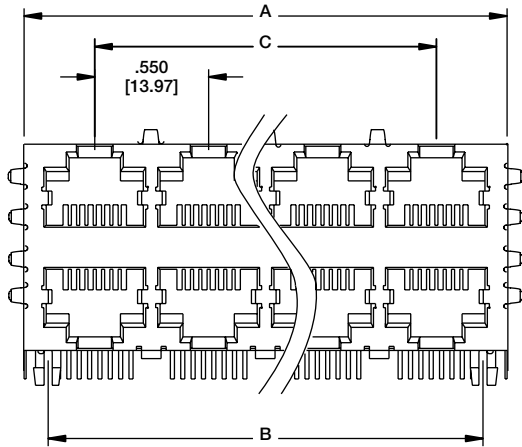

MTJG-8-88JX1-FSG-PG

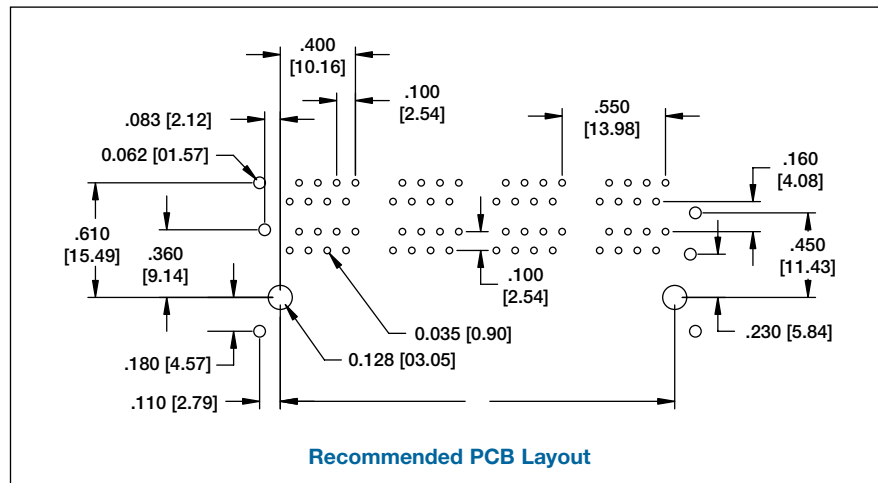

Recommended PCB Layout

PART NUMBER	PORTS	DIMENSIONS		
		A	B	C
MTJG-2-88JX1-FSG-PG	2 X 1	.679 [17.25]	.450 [11.43]	—
MTJG-4-88JX1-FSG-PG	2 X 2	1.230 [31.25]	1.00 [25.40]	.550 [13.97]
MTJG-6-88JX1-FSG-PG	2 X 3	1.780 [45.21]	1.549 [39.34]	1.100 [27.94]

PART NUMBER	PORTS	DIMENSIONS		
		A	B	C
MTJG-8-88JX1-FSG-PG	2 X 4	2.33 [59.18]	2.100 [53.34]	1.650 [41.91]
MTJG-12-88JX1-FSG-PG	2 X 6	3.43 [87.10]	3.200 [81.28]	2.750 [69.85]
MTJG-16-88JX1-FSG-PG	2 X 8	4.537 [115.25]	4.30 [109.22]	3.850 [97.79]

**COMBINATION
MOD JACK &
DUAL USB WITH
INTEGRATED
MAGNETICS**

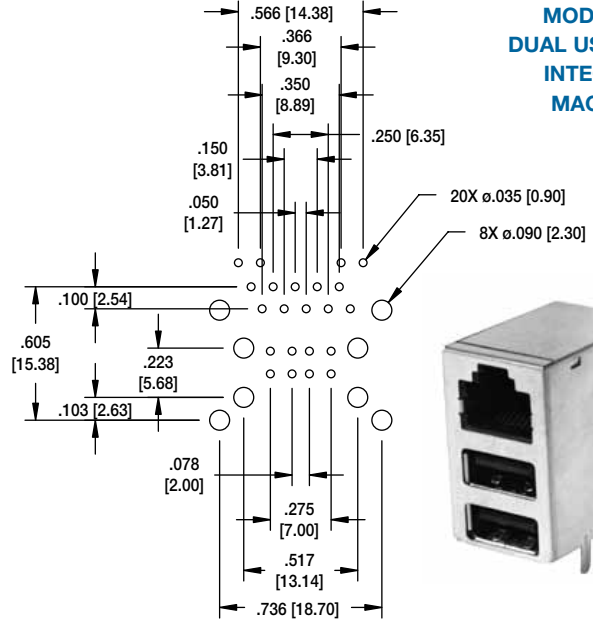
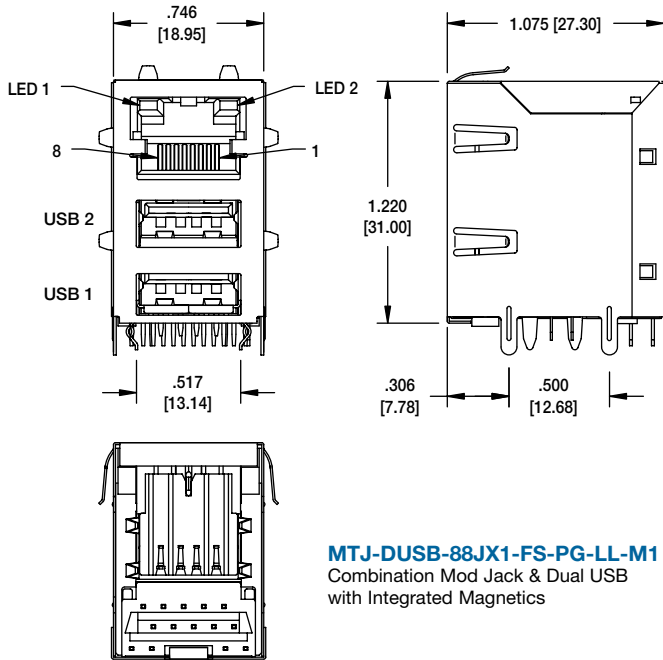

LED CONFIGURATION (Add suffix to end of part no.)		
SUFFIX	LED 1	LED 2
LA	YELLOW	YELLOW
LD	GREEN	GREEN
LG	YELLOW	GREEN
LH	GREEN	YELLOW
LI	ORANGE/GREEN	ORANGE/GREEN
LP	YELLOW/GREEN	YELLOW/GREEN
LQ	YELLOW/GREEN	—
L11	RED	GREEN

OTHER LED COLOR
COMBINATIONS AVAILABLE

LED SPECIFICATION			
STANDARD LED	WAVE LENGTH	FORWARD VOLT / CURRENT	TYP
GREEN	565 nm	5.5V / 20mA	5.0V
YELLOW	590 nm	5.5V / 20mA	5.0V
ORANGE	610 nm	5.5V / 20mA	5.0V
RED	637 nm	5.5V / 20mA	5.0V

AVAILABLE WITH MAGNETIC
TRANSFORMERS M1, M3, M4,
M5, M6, M7, M8, M9, M10, M11,
M12, M13, M16 & M20
See Pgs 44-45:

ORDERING INFORMATION FOR JACKS WITH INTEGRATED MAGNETICS & LEDs

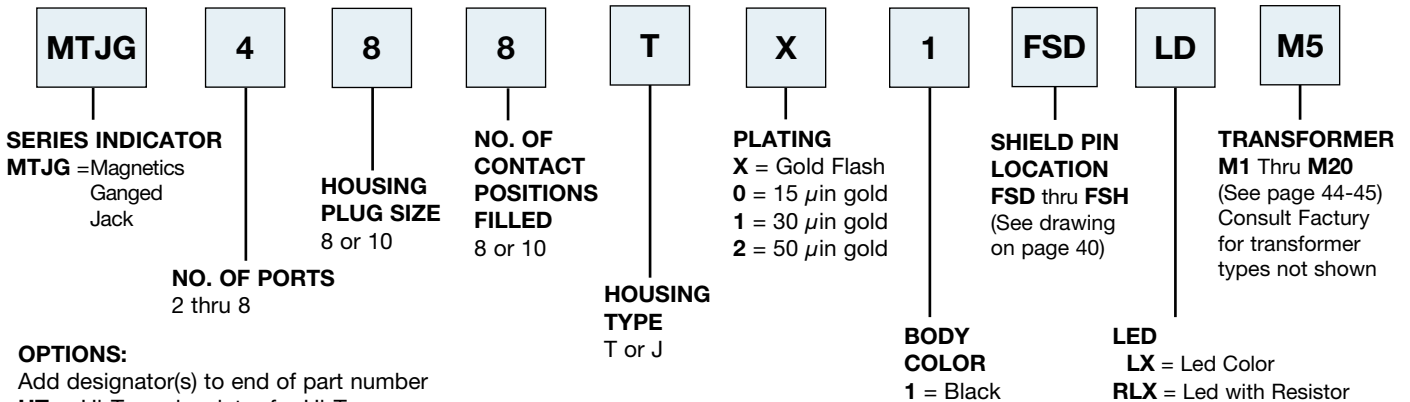

OPTIONS:

Add designator(s) to end of part number
HT = Hi-Temp insulator for Hi-Temp soldering processes up to 260°C
PG = Panel ground tabs

