

INTRODUCTION:

Adam Tech PLCC Series Sockets are designed to convert plastic leaded chips to a thru-hole PCB format on a .100" centerline grid. They conform to JEDEC MS 016 and MS 018 pin count standards. Adam Tech's superior precision stamped contact design provides consistent, high retention contacts for all size chips. Chip exchanges or replacements are easily made with Adam Tech's chip remover part no. PLCC-EXT.

FEATURES:

- Full range of sizes from 20P ~ 100P
- Consistent, uniform high retention contacts
- Compatible with wide range of chip sizes
- No solder wicking design
- Hi Temp PPS insulator version available

MATING PLASTIC LEADED CHIPS:

All EIA / JEDEC plastic leaded chips

SPECIFICATIONS:

Material:

Standard Insulator: PBT, Glass reinforced, rated UL94V-0
Optional Hi-Temp insulator: PPS
Insulator Color: Black (Brown for PPS)
Contacts: Phosphor Bronze

Contact Plating:

Tin over copper underplate overall

Electrical:

Operating voltage: 250V AC max.
Current rating: 1 Amp max.
Contact resistance: 30 mΩ max. initial
Insulation resistance: 1000 MΩ min.
Dielectric withstanding voltage: 500V AC for 1 minute

Mechanical:

Insertion force: 6.35 oz max.
Withdrawal force: 1.0 oz min

Temperature Rating:

Operating temperature: -20°C to +85°C
Soldering process temperature:
Standard insulator: 235°C
Hi-Temp insulator: 260°C

PACKAGING:

Anti-ESD plastic tubes

APPROVALS AND CERTIFICATIONS:

UL Recognized & CSA Certified, File no. E224053



ORDERING INFORMATION

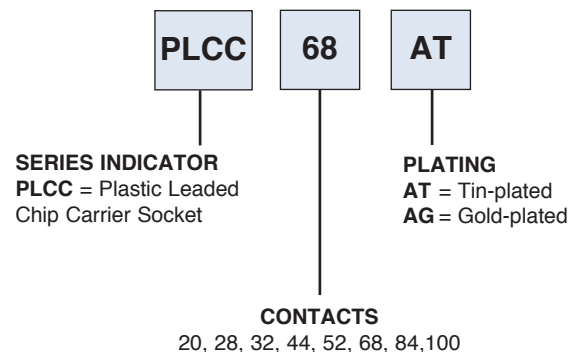

OPTIONS:

Add designator(s) to end of part number
HT = Hi-Temp Polyphenylene Sulfide (PPS) Insulator
Material for hi-temp soldering process up to 260°C

