

#### INTRODUCTION:

Adam Tech HMCA Series Card Edge Connectors include Standard and Express versions designed for PCB's in Peripheral Component Interconnect (PCI) applications. Each is manufactured in a four row, high density package which is completely compatible to industry standards and has specially engineered contacts which provide a very short electrical path between boards. Adam Tech card edge connectors are designed for high performance with solid board pegs and precision located, selectively gold plated contacts which are ideal in high speed, increased bandwidth applications

#### FEATURES:

- PCI and PCI Express Versions
- High density compact designs
- Industry standard PCI compatible
- Special contact design reduces electrical path
- Selectively plated contacts
- Open bottom for after solder cleaning

#### MATING PC BOARDS:

All .050" centerline printed circuit board pads with a thickness of .062" to .072"

#### SPECIFICATIONS:

##### Material:

Standard insulator: PPS, 30% glass reinforced, rated UL94V-0

Optional Hi-Temp insulator: Nylon 6T, rated UL94V-0

Insulator Color: Dark Brown (White for 120 pos.)

Contacts: Phosphor Bronze

##### Contact Plating:

Gold flash (30  $\mu$ in optional) over Nickel underplate on contact area, tin over copper underplate on tails.

##### Electrical:

Operating voltage: 125V AC max.

Current rating: 1 Amp max.

Contact resistance: 30 m $\Omega$  max. initial

Insulation resistance: 1000 M $\Omega$  min.

Dielectric withstanding voltage: 500V AC for 1 minute

##### Mechanical:

Insertion force: 7 oz max.

Withdrawal force: 0.9 oz min

##### Temperature Rating:

Operating temperature: -55°C to +105°C

Soldering process temperature:

Standard insulator: 235°C

Hi-Temp insulator: 260°C

#### PACKAGING:

Anti-ESD plastic trays

#### SAFETY AGENCY APPROVALS:

UL Recognized & CSA Certified, File no. E224053

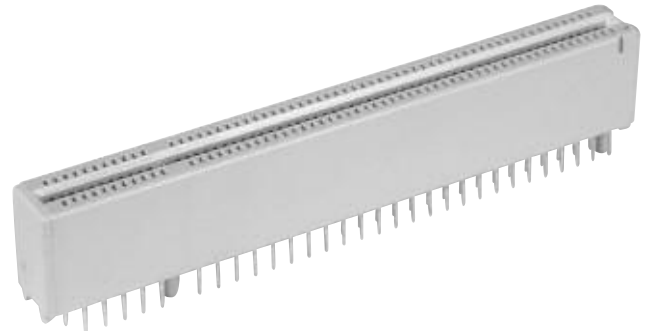

#### ORDERING INFORMATION

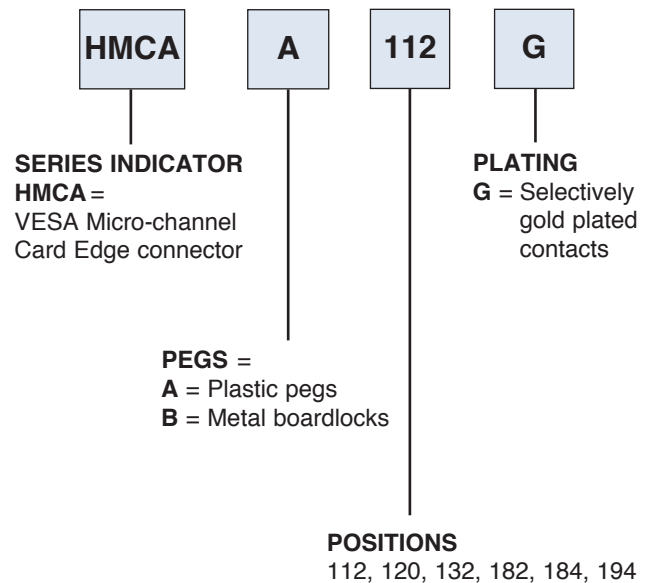

#### OPTIONS

Add designator(s) to end of part number

**30** = 30  $\mu$ in gold plating in contact area

**HT** = Hi-Temp insulator for Hi-Temp soldering processes up to 260°C

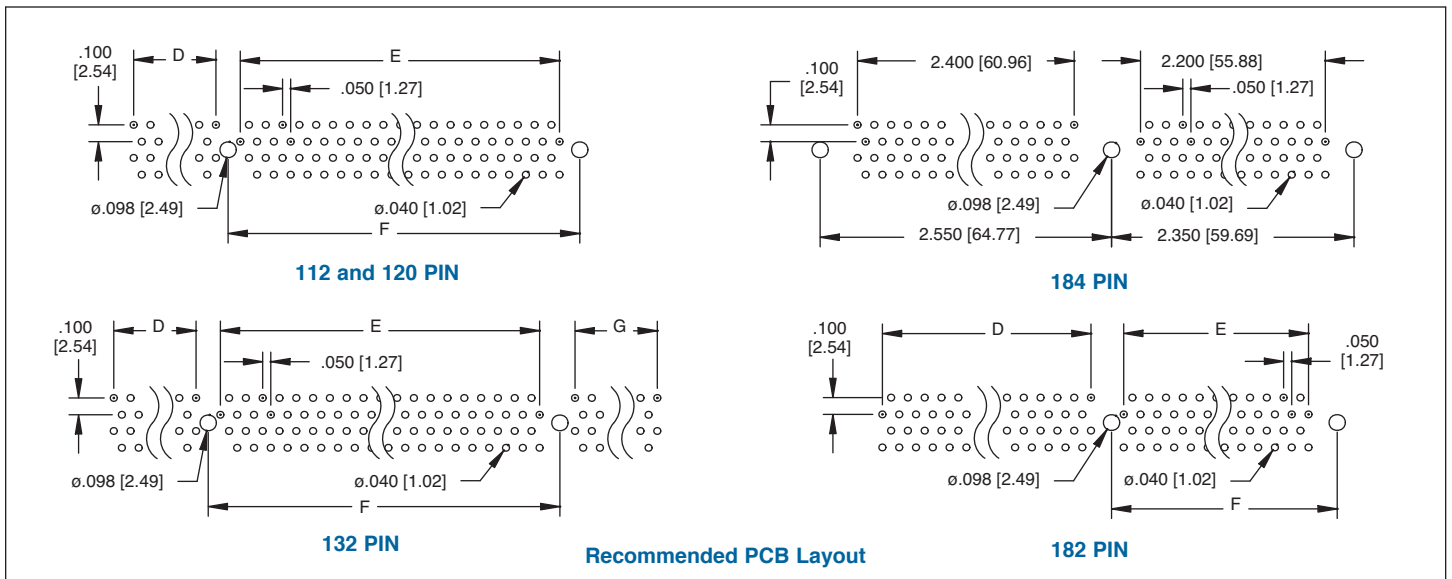
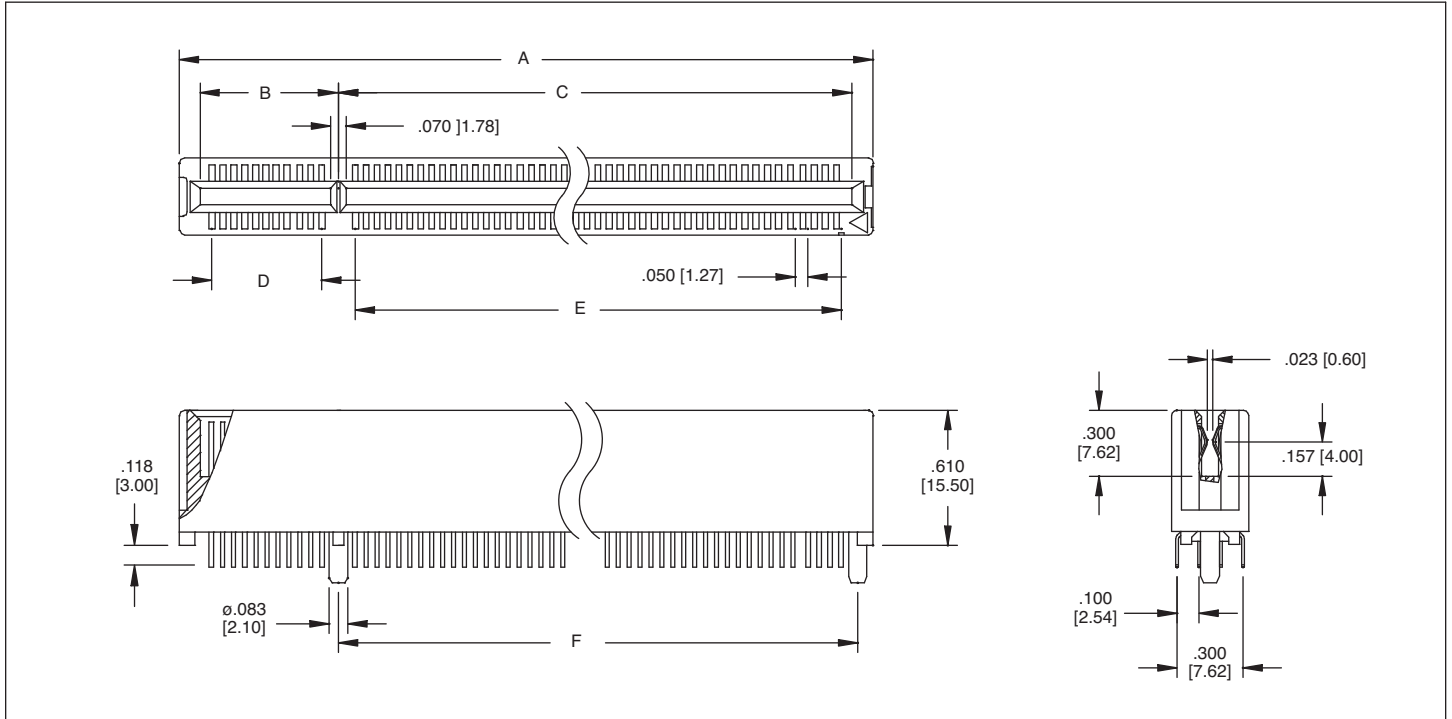

Unit: Inch [mm]

Part No. & Positions	Dimensions						
	A	B	C	D	E	F	G
HMCA-112-G	3.140 [79.76]	0.625 [15.88]	2.325 [59.06]	0.500 [12.70]	2.200 [55.88]	2.232 [56.69]	—
HMCA-120-G	3.340 [84.84]	0.625 [15.88]	2.525 [64.14]	0.500 [12.70]	2.400 [60.96]	2.550 [64.77]	—
HMCA-132-G	3.740 [95.00]	0.625 [15.88]	2.925 [74.30]	1.834 [46.60]	2.200 [55.88]	2.350 [59.69]	0.450 [11.43]
HMCA-182-G	4.890 [124.21]	2.175 [55.25]	2.525 [64.14]	2.050 [52.07]	2.050 [52.07]	2.550 [64.77]	—
HMCA-194-G	5.290 [134.37]	2.175 [55.25]	2.925 [74.30]	2.050 [52.07]	2.200 [55.88]	2.350 [59.69]	0.450 [11.43]

### INTRODUCTION:

Adam Tech HDCE Series EISA (Extended Industry Standard Architecture) Card Edge Connectors are .050" pitch 188 position dual level contact connectors specifically designed to mate with AT, XT and PC expansion cards. Our precision formed High Reliability contact system is contained within a Hi-Temp PPS body which features a close tolerance polarizing slot and card edge lead-in area for superior mating.

### FEATURES:

High density .050" Centerlines  
Compatible with PC, XT & AT  
Durable Long Life cycle contacts  
High Pressure Contacts for Low Level Circuits

### MATING PC BOARDS:

All .050" centerline printed circuit board pads with a thickness of .062" to .072"

### SPECIFICATIONS:

#### Material:

Standard insulator: PPS, 30% glass reinforced, rated UL94V-0  
Optional Hi-Temp insulator: Nylon 6T, rated UL94V-0  
Insulator Color: Dark Brown (Black optional)  
Contacts: Phosphor Bronze

#### Contact Plating:

Gold flash (30  $\mu$ in optional) over Nickel underplate on contact area, tin over copper underplate on tails.

#### Electrical:

Operating voltage: 125V AC max.  
Current rating: 3 Amps max.  
Contact resistance: 20 m $\Omega$  max. initial  
Insulation resistance: 1000 M $\Omega$  min.  
Dielectric withstanding voltage: 500V AC for 1 minute

#### Mechanical:

Insertion force: 7 oz max.  
Withdrawal force: 0.9 oz min

#### Temperature Rating:

Operating temperature: -55°C to +105°C  
Soldering process temperature:  
Standard insulator: 235°C  
Hi-Temp insulator: 260°C

### PACKAGING:

Anti-ESD plastic trays

### APPROVALS AND CERTIFICATIONS:

UL Recognized & CSA Certified, File no. E224053



### ORDERING INFORMATION

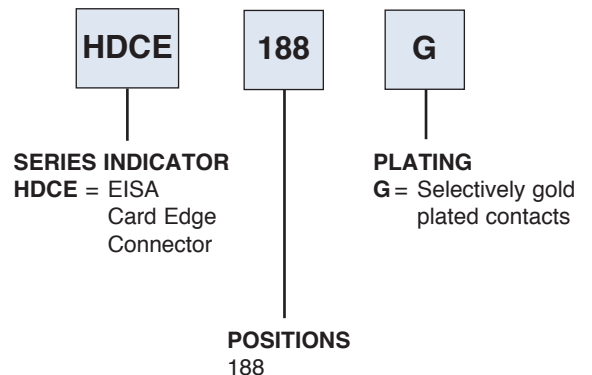

### OPTIONS:

Add designator(s) to end of part number

**30** = 30  $\mu$ in gold plating in contact area

**BK** = Black color insulation

**HT** = Hi-Temp insulator for Hi-Temp soldering processes up to 260°C

## HDCE-188-G

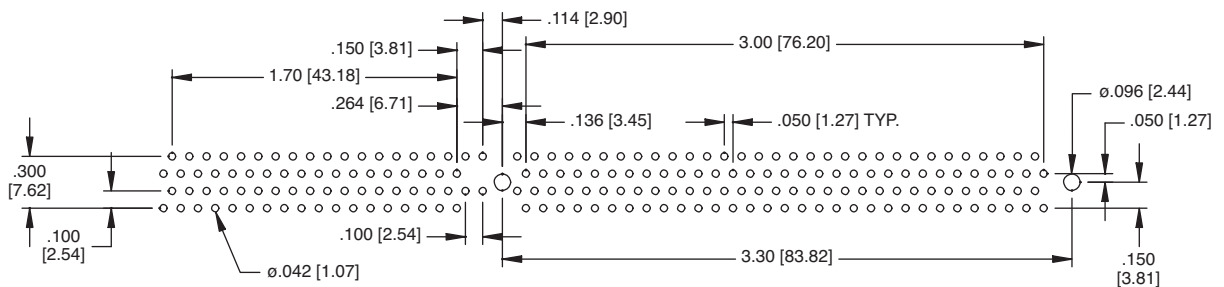
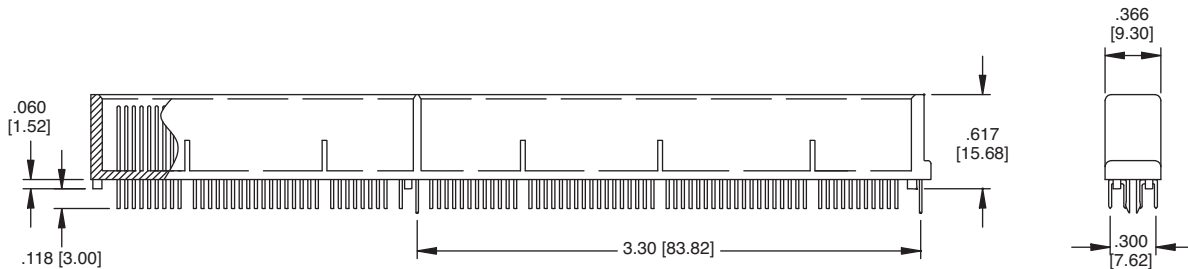
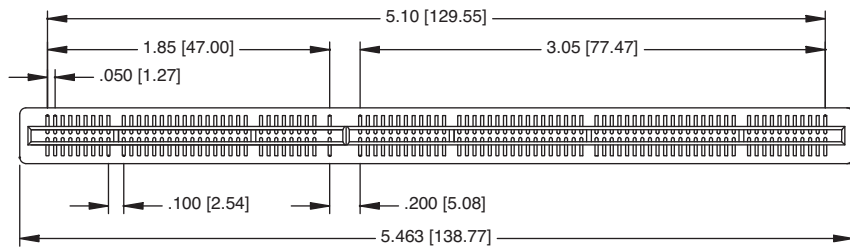

Recommended PCB Layout